



Installation instructions

Fireplace inserts





PREFACE - QUALITY PHILOSOPHY

You have decided to purchase a SPARTHERM fireplace insert. Thank you for showing confidence in our product.

In a world of surplus and mass production, our company stands for the values expressed by our owner, Gerhard Manfred Rokossa:

"High technical quality combined with contemporary design and service to the customer and their satisfaction and further recommendation."

We offer first-class products that touches your customers emotionally and address their feelings such as the feeling of safety, security and comfort. In order to become completely familiar with your purchase in the shortest possible time, we recommend that you read through these installation instructions carefully. In addition to detailed instructions on installing your product, this document also contains important safety information, advice on how to keep your fireplace insert in good condition, valuable tips and helpful recommendations. Should you have any further questions or problems, please contact us directly. We are always happy to receive your questions, suggestions and any critic.

On behalf of the whole team at Arcadia, we wish you every success with the installation of your fireplace insert and many hours of happiness in front of your new fire.

The SPARTHERM team

G.M. Rokossa

CONTENT INSTALLATION INSTRUCTIONS

1. General instructions	4	6. Installation guidelines	16
1.1 Locking function of the combustion chamber door	5	6.1 Important instructions for installing with window frame	16
1.1.1 Conversion, locking function of the combustion chamber door	5	6.2 Expansion gap between the casing and the fireplace insert	18
1.2 Conversion, door locking types	6	6.3 Fireplace apron	19
1.2.1 Pivoted combustion chamber door	6	6.4 Connecting piece	19
1.2.2 Push-up combustion chamber door in the position not installed	7	6.5 Heat dissipation	19
1.2.3 Push-up combustion chamber door in the position installed	8	6.5.1 Hot air systems	19
1.3 Assembly sequence	9	6.5.2 Fireplace systems with heating gas lines prepared by a craftsman	20
2. Basic requirements for setting up a fireplace system	9	6.5.3 Closed fireplace system casing	20
3. Installation point and combustion air supply	9	7. General installation instructions for installation spaces made from non-combustible construction materials	20
3.1 Basic requirements on the installation point	9	7.1 Floors and attachment walls	21
3.2 The operation of the fireplace system is not at danger if	9	7.2 Floors, attachment walls and ceiling	21
3.3 Fireplace systems must not be installed	10	8. General installation instructions for installation spaces made from combustible construction materials	22
3.4 Combustion air supply	10	8.1 Floors, attachment walls and ceiling	22
3.5 Combustion air piping	11	8.2 Insulation	23
4. Exhaust circuit shut-off device	11	9. Cleaning the fireplace systems	23
4.1 Throttling device	11	10. Special information for Spartherm fireplace inserts	23
5. Fire protection on / in the fireplace system	11	10.1 Flue gas outlet	23
5.1 Special precautions for fire protection	11	10.2 Fireplace insert with push-up combustion chamber door	24
5.1.1 Floor coverings near the fireplace	11	10.3 Carrying aids	24
5.1.2 Combustible components	13	11. Technical details	25
5.1.3 Sill beam made of hardwood	14		
5.2 Concrete and reinforced concrete load-bearing components	14		
5.3 Wooden beams	14		
5.4 Insulating layers	14		
5.4.1 Insulating material thickness	14		
5.4.2 Protecting the mounting wall with a stud wall	15		

1. GENERAL INSTRUCTIONS

These installation instructions comply with the provisions outlined in DIN EN 13229 "Solid-fuel fireplaces".

All national and regional regulations, standards and norms, methods of installation and material specifications must be observed. Naturally, all our fireplace inserts are subject to our own quality criteria, from incoming goods inspection to the approval before shipping.

Small children, elderly or infirm persons:

As is the case with all heating devices, it is expedient that you attach a protective fixture for these groups of persons, as the view pane and the cladding parts of the fireplace can become extremely hot!

→ Danger of burn injuries! ←

Never leave these groups of persons unattended near the fireplace insert when a fire is burning or has just been extinguished! Please ensure that persons belonging to these groups are made aware of the dangers.

No combustible objects, materials or substances should be placed on or near the free surfaces of the fireplace system. Do not attempt to dry out clothing on the hot tiles of the fireplace system. When drying clothes, use a proper drying stand or clothes' horse and ensure it is placed outside the area of direct radiant heat!

The surfaces of your fireplace system such as the operating handles, doors, viewing glass, etc. are quickly made hot by heat energy released during the combustion process. Do not attempt to touch these components without adequate protection (i.e. **heat-resistant gloves**).

The fireplace insert must never be modified! In particular, never insert any installation components into the combustion chamber, combustion passages or flue gas flue that have not expressly approved by SPARTHERM. Your fireplace warranty will be rendered invalid by any fireplace modification carried out using components not approved by Arcadia.

You may find that extractor hoods, ventilation equipment, etc., installed in the same room (or linked space) as your fireplace or stove, have a negative effect on the fireplace insert (such as the release of smoke into the room). These devices should not be used at the same time as your fireplace or stove, without first ensuring that the necessary room heating system precautions have been taken.

When using more than one fireplace in a single room or linked space, ensure that sufficient air is available for complete combustion!

This is a temporary fire area thus, longer continuous burning is not achieved by piling up the fire repeatedly. Continuous burning without piling up the fire in-between cannot be achieved even through withdrawal of the combustion air and is not permitted.

Transport damage: immediately on arrival, please check the goods delivered (visual inspection). Make a note of any damage on your delivery document. Inform your stove or fireplace fitter of the damage before the installation work begins. When installing the casing of your fireplace insert, take care to protect the viewing glass from damage or soiling.

The technical data of your fireplace insert can be found from Seite 4.

1.1 LOCKING FUNCTION OF THE COMBUSTION CHAMBER DOOR

The suitability of the fireplace insert for multiple allocation (two or more fireplace inserts on the same chimney) depends on if the door has a self-locking function:

Self-locking door function: fireplace insert is suitable for multiple allocation

No self-locking door function: multiple allocation is not permitted, thus, the fireplace insert must be connected to its own chimney line.

Note: with a multiple allocation of the chimney, this must be built and designed accordingly.

In doing so, the question must be asked if the fireplace insert is an "open fireplace" or not. In Germany, an "open fireplace" is not subject to the emission requirements of the BImSchV level 1 (Ordinance in the Implementation of the Federal Emission Control Act), but may be operated "occasionally". The manufacturer specifies the mode of operation of the fireplace insert and determines if the device can be used correctly when open and thus must be termed as "open chimney": open burning permitted according to the manufacturer: open fireplace only with occasional operation of open burning according to the manufacturer is not permitted: closed chimney, not limitations in use

Note: the former terms from "Design A1" or "Design A" that are derived from the standard DIN 18895 that is no longer valid frequently resulted in the mixture of the features specified above and are no longer valid.

Generally, Spartherm fireplace inserts are operated correctly when they are closed thus, with the exception of feeding or cleaning, the fireplace insert doors must be shut.

Fireplace inserts for burning with combustion chamber door open tested by ourselves are marked in the installation instructions for the fireplace insert enclosed separately in the technical data.

When operating on a chimney with single allocation (one fire area for each chimney line), the operator can choose if the combustion chamber door is self-locking or not self-locking. The correct locking of the combustion chamber door when operating the fire are always the responsibility of the operator and must be observed.

1.1.1 CONVERSION, LOCKING FUNCTION OF THE COMBUSTION CHAMBER DOOR

Spartherm fireplace inserts that can be pushed-up are not carried out with a self-locking combustion chamber door when delivered, folding fireplace inserts are carried out with a self-locking combustion chamber door. The door locking type with push-up fireplace insert with non-locking combustion chamber door can be converted into a self-locking combustion chamber door by removing the door counter-weights. The door locking type with folding fireplace insert with non-locking combustion chamber door can be converted into a self-locking combustion chamber door by relieving the door closing spring.

The procedure for converting the door lock type can be found in the corresponding installation instructions for the fireplace inserts.

1.2 CONVERSION, DOOR LOCKING TYPES

1.2.1 PIVOTED COMBUSTION CHAMBER DOOR

Conversion of a self-locking pivoted combustion chamber door to a non-pivoted combustion chamber door by relieving the door lock spring.

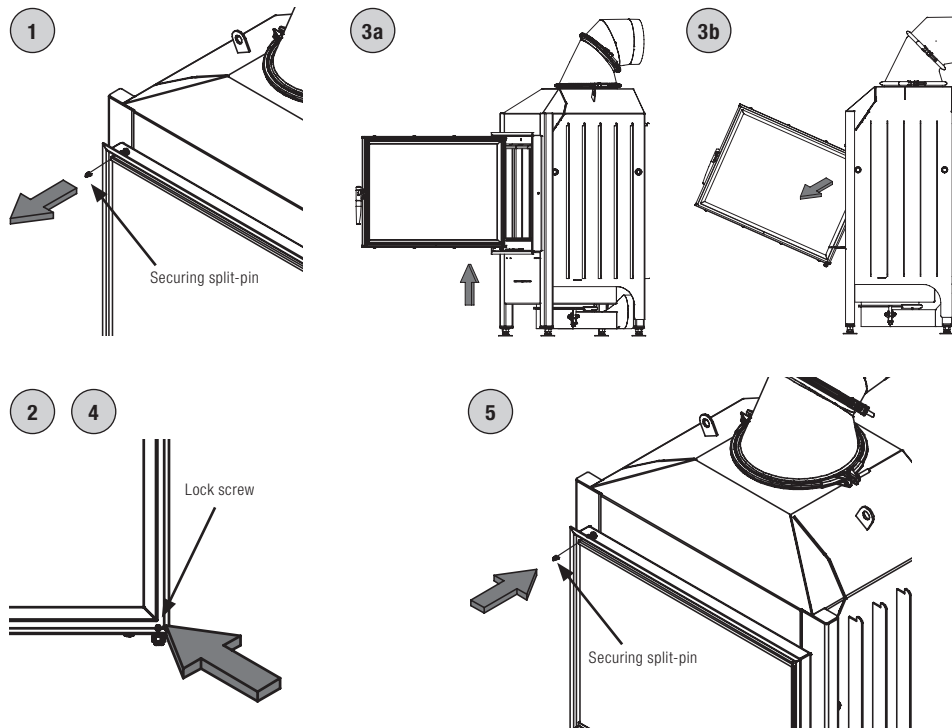

1. Remove the securing split-pin between the frame and door.
2. Secure the door locking spring (Allen key 2.5). Tighten the locking screw located at the bottom right in the corner of the door at the bottom pivot point. They may be located a little under the grey cord seal. The work steps to be carried out must not damage the seal!
3. Hang-out the combustion chamber door.
4. Relieve the locking screw (Allen key 2.5). A significant clicking should be heard.
5. Insert the combustion chamber door, mount the securing split-pin.

1.2.2 PUSH-UP COMBUSTION CHAMBER DOOR IN THE POSITION NOT INSTALLED

Conversion of a non-self-locking combustion chamber door to a combustion chamber door by removing the counter weights. Carry out the fireplace inserts with two weight shafts in the same procedure on both sides.

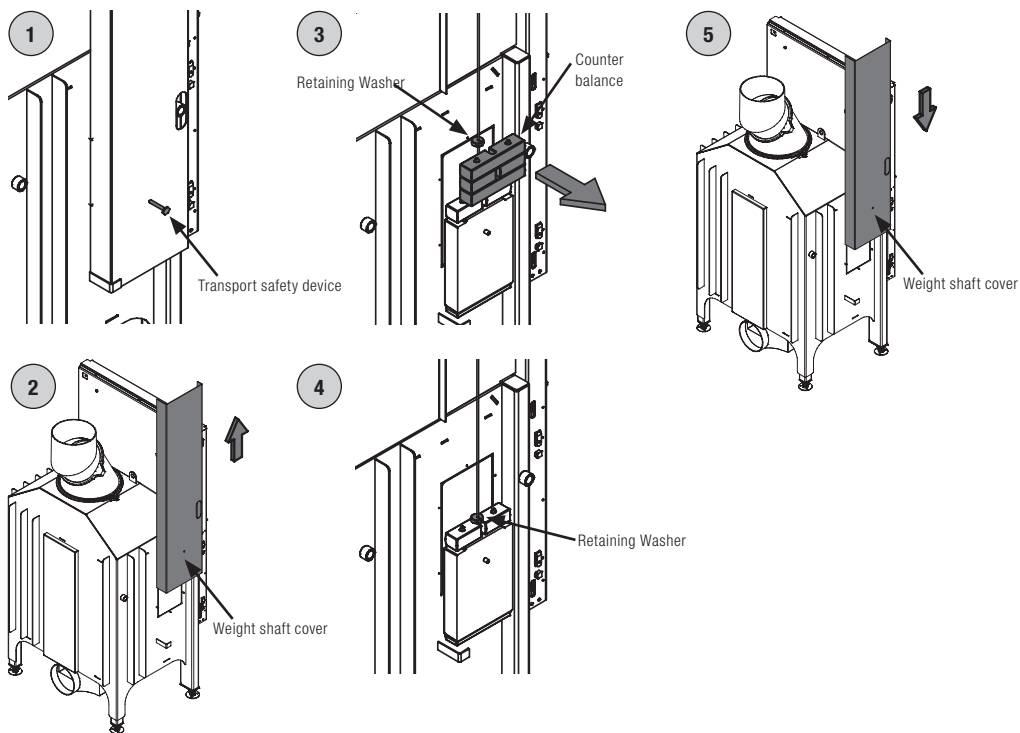

1. Removing the transport safety device and fastening screws.
2. Pull the weight shaft cover upwards.
3. Release the locking ring (Allen key 2.5). Remove the necessary counter-weights. The number of weights to be removed must be selected in such a manner that the door closes slowly with a constant speed, check the function.
4. Tightening the locking ring (Allen key 2.5).
5. Mount the weight shaft cover and secure with a fastening screw(s).

1.2.3 PUSH-UP COMBUSTION CHAMBER DOOR IN THE POSITION INSTALLED

Conversion of a non-self-locking combustion chamber door to a self-locking combustion chamber door. Carry out the fireplace inserts with two weight shafts in the same procedure on both sides!

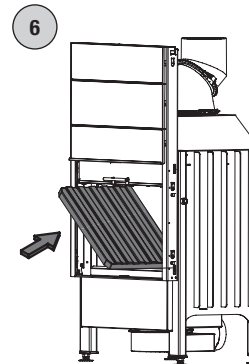
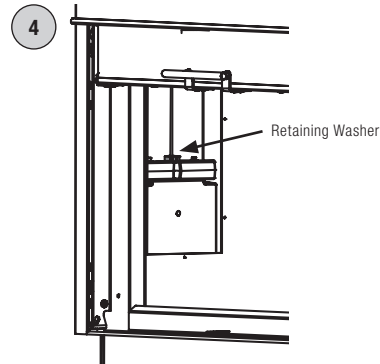
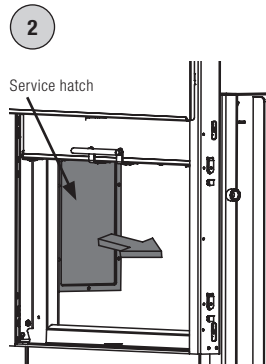
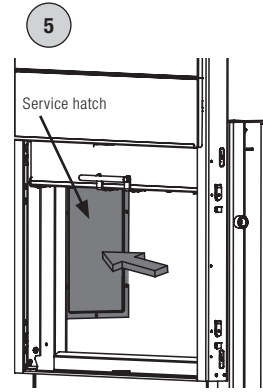
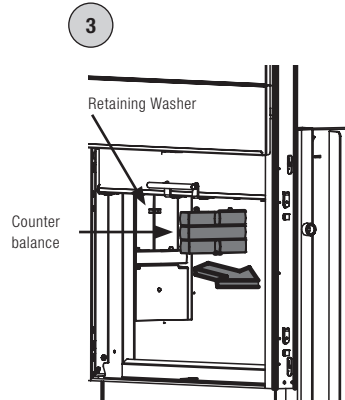
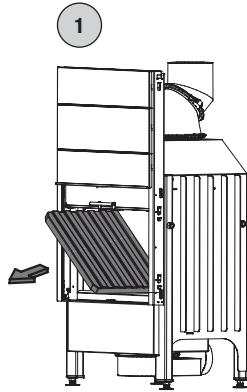

1. Remove the wall cladding.
2. Remove the service hatch.
3. Release the locking ring (Allen key 2.5). Remove the necessary counter-weights. The number of weights to be removed must be selected in such a manner that the door closes slowly with a constant speed, check the function.
4. Tightening the locking ring (Allen key 2.5).
5. Mount the service hatch.
6. Reinsert the wall cladding.

1.3 ASSEMBLY SEQUENCE

1. For fireplace inserts with push-up combustion chamber door, first unscrew the locking screws of the counter weights!
2. If required, use the clamp or the one-hand clamping lock included to attach the external combustion air swivel to the adapter in the desired position.
3. The fireplace insert has to stand absolutely vertical and horizontal!
4. Horizontal connection to the chimney is possible by rotating the flue gas dome. To do this, open the clamp, put the flue gas dome in position and clamp it in place again.

2. BASIC REQUIREMENTS FOR SETTING UP A FIREPLACE SYSTEM

Before installing the fireplace insert, make sure that the air controls function perfectly and repair if necessary. Consult a local expert to establish the condition of the chimney and combustion air intake before beginning installation. Note and apply DIN 18160 and DIN 18896. The responsible standard DIN EN 13229 must be used. Every fireplace system requires its own chimney. Multiple allocation is only permitted for chimney systems with self-locking combustion chamber door.

The chimney calculation is based on DIN 4705 T1, T2 or EN 13384-1 with the value triplet specified in these instructions. The optionally available convection jacket is not required for tiled fireplaces. The fireplace system must be set up as per the professional tiled stoves and ventilation engineer regulations (TROL-Richtlinien für den Bau von Kachelöfen, available from the German Central Association for Sanitation, Heating, and Air Conditioning (ZVSHK), Rathausallee 5, 53729 St. Augustin, Germany).

3. INSTALLATION POINT AND COMBUSTION AIR SUPPLY

3.1 BASIC REQUIREMENTS ON THE INSTALLATION POINT

Fireplace systems may only be installed in rooms and places in which the location, construction situation and type of use do not lead to hazards. In particular, when the model is dependant on indoor air, sufficient combustion air must flow into the room in which the fireplace is set up. The floor area must be of sufficient size and of a suitable design to allow an open fireplace to be used correctly.

3.2 THE OPERATION OF THE FIREPLACE SYSTEM IS NOT AT DANGER IF

- the chimney system has integrated safety equipment that automatically and reliably prevents the negative pressure in the installation room.
- the required combustion air volume flow and the volume flow of the ventilation system as a whole do not require any greater negative pressures than 0.04 mbar in the installation room and the room and the rooms of the ventilation network.

3.3 FIREPLACE SYSTEMS MUST NOT BE INSTALLED

- in stairways, unless they are in residential buildings with two or fewer flats.
- in hallways with general access.
- in garages.
- in rooms in which highly combustible or potentially explosive substances or mixtures are processed, stored or manufactured in quantities that would be hazardous in the event of ignition or explosion
- fireplace systems in rooms or flats that are ventilated through ventilation systems or warm air heating through the use of fans, unless the safe operation of the fireplace system is ensured.

3.4 COMBUSTION AIR SUPPLY

Fireplace systems may only be installed in rooms with at least one door or window opening to the outside of the building or in rooms, directly or indirectly "linked with other rooms by the same combustion air". When installing fireplaces in apartments or building units for sundry use, only the rooms in the same apartment or building unit are deemed to be "linked by the same combustion air".

Fireplace systems may only be installed in the aforementioned rooms, where the flow of combustion air is at least 360 m³ per hour and the combustion chamber opening at least x m² in area. If other fireplace systems are installed in the same installation room or in rooms that are joined to the installation room, according to technical guidelines the fireplace systems must be provided with at least 540 m³ of combustion air per hour and x m² combustion chamber, and the other types of fireplace systems must have at least 1.6 m³ of combustion air per hour and per kW total nominal heat output at a calculated pressure difference of 0.04 mbar with respect to atmospheric conditions. An air flow velocity of around 0.15 m/s is generally

used for calculating supply pipe diameter. For a fireplace insert with a door height of 51x60 cm, a feed pipe cross-sectional area of 175 cm² is required, i.e. a supply pipe diameter of ca. 15 cm.

Where the volume of combustion air at the installation is inadequate (e.g., in houses with ventilation systems), a combustion air feed pipe must be connected to the appliance. The combustion air feed pipe is designed to supply the appliance with air from another room. (The source room must have a plentiful supply of air. If in doubt, consult a local expert and refer to the FeuVo and DIN 18896).

A shut-off valve must be installed, where the combustion air feed pipe runs outside the building. It must be possible to easily determine the shut-off valve setting. This arrangement allows the feed pipe to be isolated, in order to guard against the formation of condensation. The pipe must be positioned, so that any condensation formed can run out of the pipe and water or other foreign substances cannot get in.

NOTE

In the interests of providing adequate amounts of combustion air, the January 1980 issue of Furnace Regulations for instructions on system design and the May 1998 issue of Furnace Regulations for examples of working systems should be consulted. These can be found in Institute of Building Technology Report No. 3/1980, 17th. Ann. Issue (see also the commentary to DIN 18895).

3.5 COMBUSTION AIR PIPING

In accordance with local regulations (Landesbauordnung) pursuant to Article 37 Paragraph 2 of the German Model Building Code, combustion air piping crossing a fire wall in buildings with more than two fully-sized floors must be installed such that smoke or fire cannot be transmitted to other floors or fire compartments.

NOTE

For information on how to comply with the above-mentioned specifications, see the fire inspection guidelines for the fire prevention requirements of ventilation systems (draft) – January 1984 version.

4. EXHAUST CIRCUIT SHUT-OFF DEVICE

Fireplace systems with Spartherm fireplace inserts may have a cut-off device in the vent. These devices must not be self-closing and must not be positioned such as to prevent or hinder the inspection and cleaning of connecting pipework. The position of the shut-off device must be visible from the outside, e.g., from the position of the operating handle. Shut-off devices may only be installed in the exhaust manifold or collecting pipe, the flue gas pipe stub or the pipeline connecting piece. Instead of cut-off devices, fireplace inserts with combustion chamber doors can have throttle devices.

4.1 THROTTLING DEVICE

Throttling devices may only be installed in the flue gas pipe stub or pipeline connecting piece. Throttling devices must be easy to operate. They should have cross-sectional areas at the pipe of at least 20 cm² and not less than 3% of connecting pipe cross-sectional area. The throttling device setting must be readily discernible at the operating handle.

5. FIRE PROTECTION ON / IN THE FIRE-PLACE SYSTEM

5.1 SPECIAL PRECAUTIONS FOR FIRE PROTECTION

5.1.1 FLOOR COVERINGS NEAR THE FIREPLACE

With a floor covering that is not fireproof made from combustible materials (e.g., carpet, parquet, etc.), a fireproof spark protection covering made from non-combustible material (e.g., respectively loadable glass, natural stone, glazed tiles, tiles, marble, granite or other mineral construction materials) must be installed. If this material is metal, it must have a minimum thickness of 1 mm.

The flooring must be fastened down and secured against sideways movement. The spark-protection covering must be directed to the front, the height of the combustion chamber base (fire board height) must be H plus 300 mm, and must have a minimum length of 500 mm.

If a log guard (not included) with a height of at least 10 cm is fitted, the minimum distances listed above are sufficient and can be measured from the log guard.

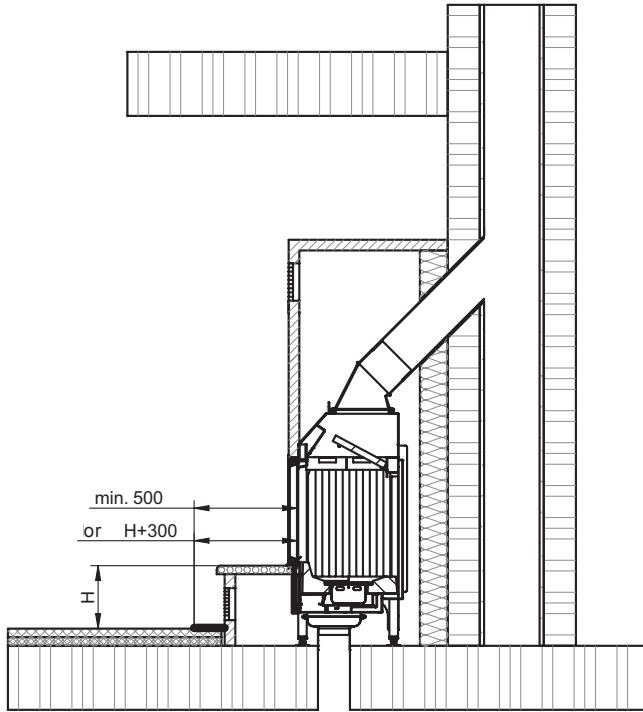

The figure shows the installation situation using the Varia 1V-51-4S as an example and applies as an example for all fireplace inserts.

The area starting from the straight area of direct radiant heat of the effective combustion chamber opening must also each be 300 mm to the left and right for protection reasons (see figure).

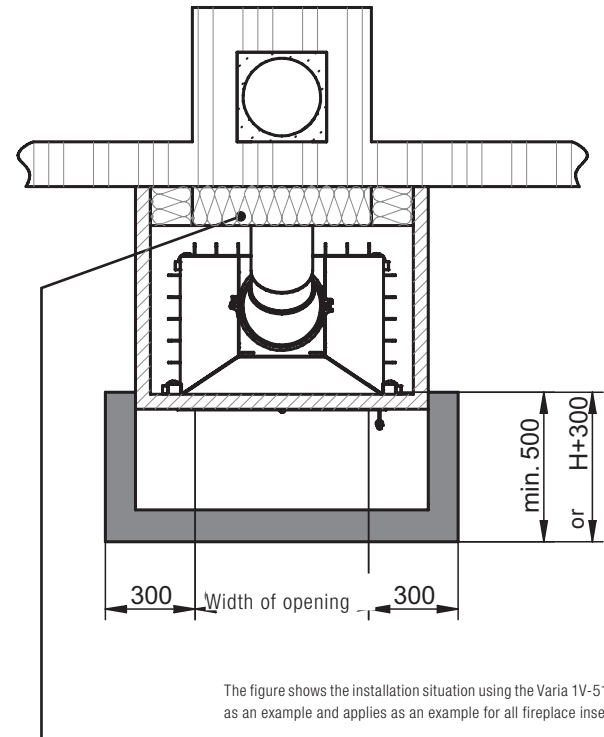

The figure shows the installation situation using the Varia 1V-51-4S as an example and applies as an example for all fireplace inserts.

If and how the chimney walls in your installation situation have to be insulated, please consult your responsible stove fitter and the chimney sweeper.

5.1.2 COMBUSTIBLE COMPONENTS

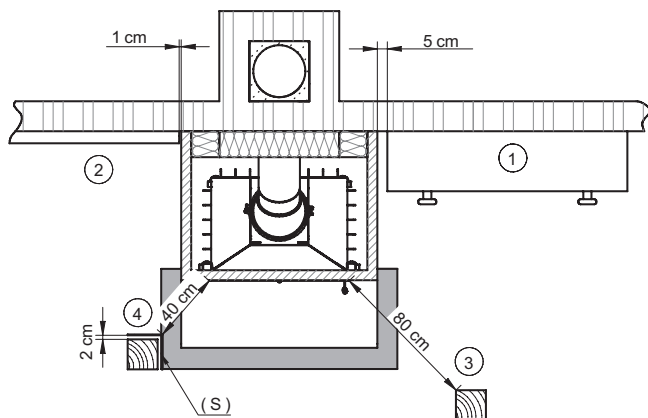

The figure shows the installation situation using the Varia 1V-51-4S as an example and applies as an example for all fireplace inserts.

- 1) A distance of at least 5 cm has to be maintained between furniture (e.g., a wardrobe) and the fireplace cladding.
- 2) A clearance of at least 1 cm is recommended for components with small contact areas (wall, floor or ceiling cladding) .
- 3) A clearance of at least 80 cm must be maintained between the front and top as well as to the sides of the combustion chamber opening and all flammable fixtures, fittings as well as built-in furniture, unless stated otherwise in component-specific safety instructions.
- 4) A reduced minimum clearance of 40 cm is allowable where ventilated radiant heat protection facilities (S) are provided on both sides. The ventilated distance to the radiant heat protecting device (S) must be at least 2 cm.

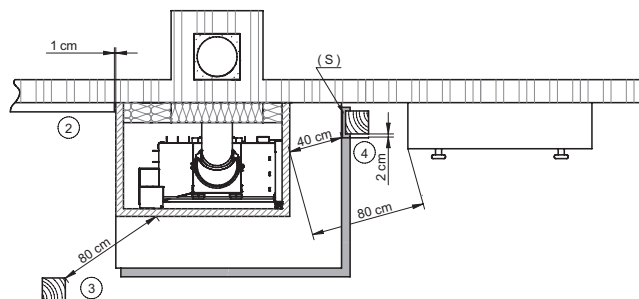

The figure shows the installation situation using the Varia 2R-80h-4S as an example and applies as an example for all fireplace inserts.

- 2) A clearance of at least 1 cm is recommended for components with small contact areas (wall, floor or ceiling cladding) .
- 3) A clearance of at least 80 cm must be maintained between the front and top as well as to the sides of the combustion chamber opening and all flammable fixtures, fittings as well as built-in furniture, unless stated otherwise in component-specific safety instructions.
- 4) A reduced minimum clearance of 40 cm is allowable where ventilated radiant heat protection facilities (S) are provided on both sides. The ventilated distance to the radiant heat protecting device (S) must be at least 2 cm.

5.1.3 SILL BEAM MADE OF HARDWOOD

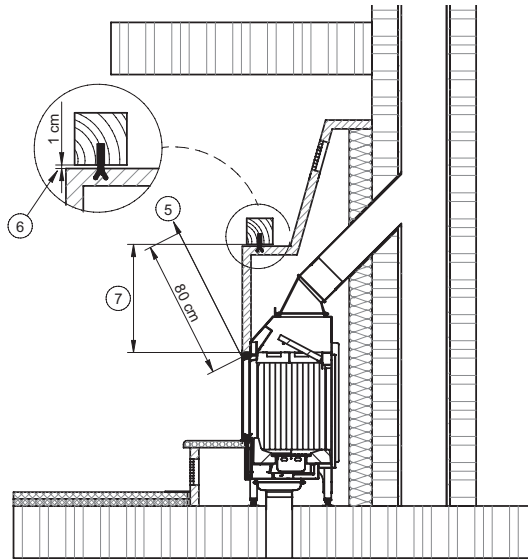

The figure shows the installation situation using the Varia 1V-51-4S as an example and applies as an example for all fireplace inserts.

5. The sill beam must be located outside the area of direct radiant heat.
- 6 A ventilated distance of 1 cm must be guaranteed. For fastening, non-combustible holders must be used, e.g., from metal. These must be arranged and carried out so that the free flow of air is not obstructed.
7. The gap between the inner edge of the combustion chamber and the sill beam has to be at least 165 cm.

5.2 CONCRETE AND REINFORCED CONCRETE LOAD-BEARING COMPONENTS

Fireplace systems must be installed so that no load-bearing structural elements made of concrete or reinforced concrete are located within 30 cm of the warm air exit points at the sides and up to a height of 50 cm above the exit points.

5.3 WOODEN BEAMS

Wooden beams may not be installed within the radiation area of the fireplace insert. Air has to circulate around with a minimum distance of 1 cm. Direct anchorage with thermal bridges is not permitted.

5.4 INSULATING LAYERS

(See chapters 7 and 8)

Mineral wool is the insulating material normally referred to in testing institute data and current insulating material regulations. Other suitable insulating materials may be used as an alternative. The materials used must be approved by the DIBt (German Institute of Building Technology) and provided with certificates or marking in confirmation thereof.

5.4.1 INSULATING MATERIAL THICKNESS

Details for the insulating material thickness can be found under chapter „11. Technical details“ on page 14.

The minimum insulation thicknesses there to combustible and protective components are only valid for components with a thermal transmittance value (U-value) $\geq 0.4 \text{ W/m}^2\text{K}$. From a U-value $< 0.4 \text{ W/m}^2\text{K}$, additional measures must be made for fire protection (see DIN 18896:2013-12).

Mats, sheets or shells of silica-based insulation material (stone or slag and ceramic fibres) of material class A1 as per DIN 4102, part 1 with an upper application limit temperature of at least 700°C when measured as per DIN 52271 and a rated gross density of 80 kg/m³ are to be used to produce the insulating layers (see Special information on insulation of the mounting wall/side wall). When using insulating materials of this type, ensure they are provided with an AGI-Q 132 code number.

The code number of the insulating material used must not, however, contain the code sequence "99"! Where the insulating layer is not held in place by walls, cladding or plating, it should be pinned into position at a maximum distance of 33 cm between the pins. Other insulation materials, e.g., gas concrete or mineral construction materials, must be approved by the German Institute of Building Technology in Berlin (DIBt). It has to be installed according to the manufacturer's instructions.

The individual insulation materials have different coefficients of thermal conductivity which means the insulation material thicknesses will vary. The required insulation material thickness can be taken from the diagram provided by the insulation material manufacturer.

Some thermal insulation materials can be used as a stud wall and insulation at one and the same time. This significantly reduces installation depth. Thermal insulation made of non-abrasive material such as, e.g., stone and slag fibre must be abrasion-resistant, e.g., with steel plate cladding, so that the recirculating air does not transport insulation particles into the room. Other thermal insulation sheets leave the factory with added abrasion resistance as required. This type of insulation material may only be installed offset and all joints must be sealed. Where multiple insulation layers are required, the joints should be arranged to overlap. The installation must be correct and abrasion-resistant. Moreover, the exact position must be permanently ensured.

5.4.2 PROTECTING THE MOUNTING WALL WITH A STUD WALL

- A protective stud wall must be constructed when installing a wall-mounted fireplace system. The stud wall must protrude at least 20 cm beyond the connecting piece.
- A stud wall is not needed, where the walls of the building are:
 - at least 11.5 cm thick
 - made from non-combustible components
 - is not a bearing concrete or reinforced concrete wall
- Stud walls are normally of brick construction, but may also be constructed from the heat-insulating panels referred to above, in order to reduce the total thickness of the stud wall and insulating material.

6. INSTALLATION GUIDELINES

6.1 IMPORTANT INSTRUCTIONS FOR INSTALLING WITH WINDOW FRAME

Generally, a difference is made in the orifice plates, self-supporting frames
in massive and folded shapes.

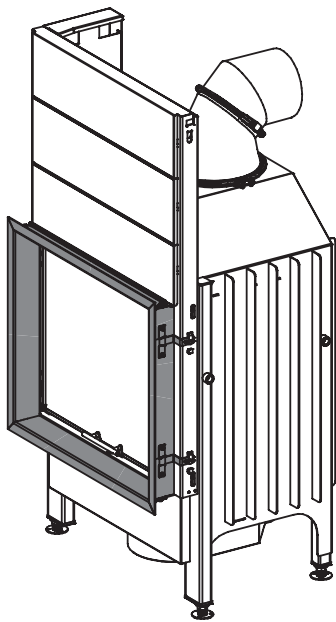

Plug-in collimator (1V fireplace inserts only)

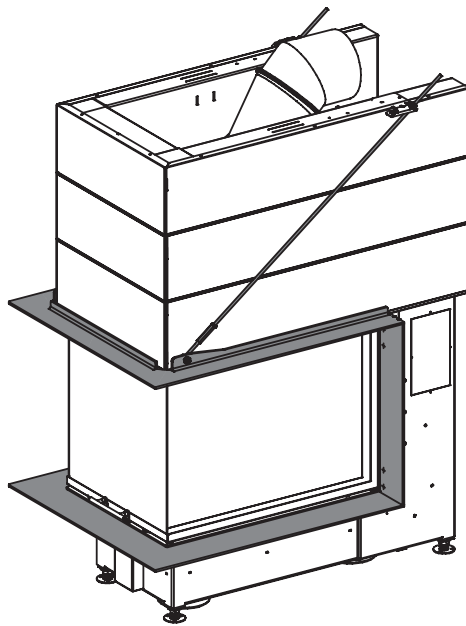

Self-supporting solid collimator

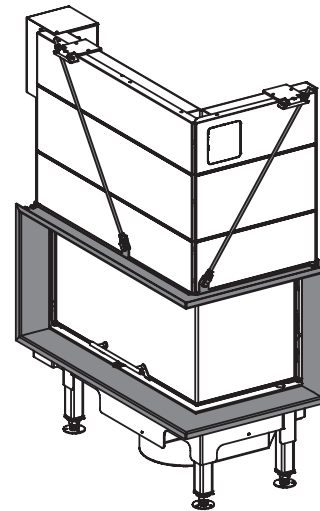

Self-supporting folded collimator

After completing the heating chamber surface, orifice plates can be pushed on and permit a clean transition from the combustion chamber opening to the heating chamber. When installing the heating chamber, take care that sufficient space is considered for mounting the collimator!

No cladding material may be mounted on orifice plates! A supporting frame must be provided for mounting the weight load.

Self-supporting beams are connected fixed to the combustion chamber and are suitable for direct wall mounting. In doing so, the maximum weight load to be applied is 200 kg. Depending on the combustion chamber type, you have the possibility to readjust the collimator when installed in order to, e.g., compensate settlements.

We recommend that insulation material, e.g., fibre glass ceramic or 2 mm fibre glass paper is inserted between the self-supporting collimator and the body of the heating chamber. This allows minor thermal expansion of the fireplace insert to be compensated.

Heating chamber bodies with self-supporting collimator should always be created with fibre glass grating / expansion joints in order to reduce the risk of expansion cracks!

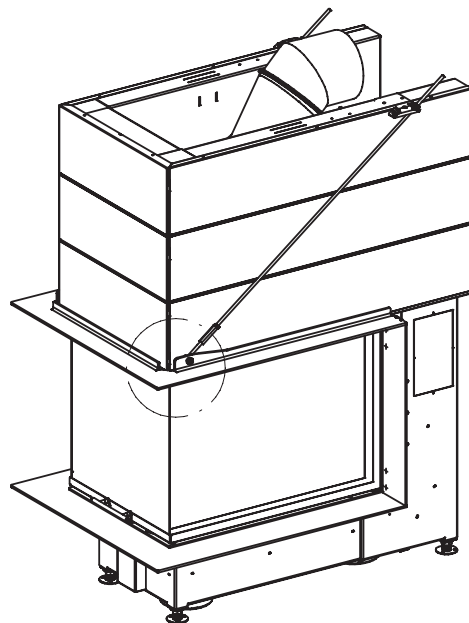
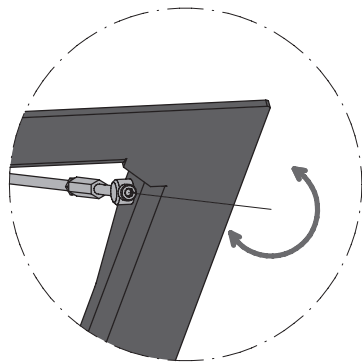

For bodies of the heating chamber flush with the ceiling or bodies with high own weight, the self-supporting collimator must be fastened on-site. For this purpose, the connecting rod must be released from the fireplace insert and secured to the body wall or on the ceiling. You can use e.g., impact anchors in combination with links made of steel for this, depending on the wall construction.

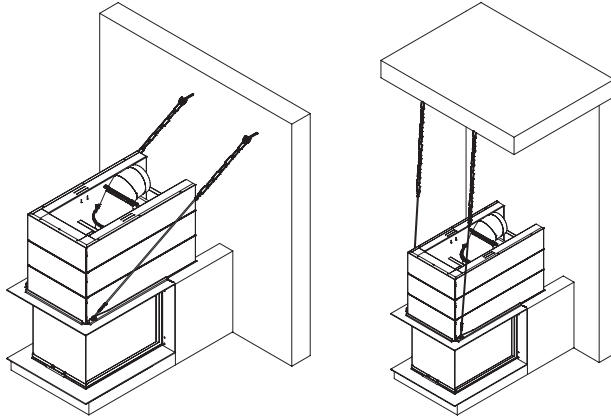

The alignment of the collimator should be carried out using a spirit level. During assembly and creating the heating chamber, take care that the supporting frame and collimator are not positioned lower than the door hood of the fireplace insert. For cleaning purposes, check the ability to push-up or pivot the combustion chamber door. **The combustion chamber door must be able to be moved freely and open without resistance.**

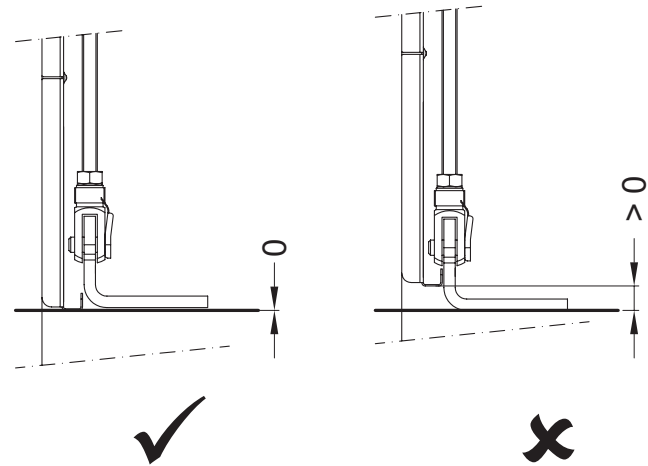

6.2 EXPANSION GAP BETWEEN THE CASING AND THE FIREPLACE INSERT

There must be no direct connection between the fireplace insert and the casing. An expansion joint must be provided and sealed by means of an appropriate sealing strip. Please note that there must be a minimum distance of 6 cm between the door frame and the fireplace hood/installation frame in order to be able to disassemble the fireplace insert door if necessary (e.g. replace the pane).

6.3 FIREPLACE APRON

A fireplace hood must never be connected directly to the fireplace insert. The apron must be self-supporting. Please note that there must be a minimum distance of 6 cm between the door frame and the fireplace hood/installation frame in order to be able to disassemble the fireplace insert door if necessary (e.g. replace the pane).

6.4 CONNECTING PIECE

The neck tube for the connection piece is on the flue dome of the fireplace insert. The connection to the chimney must be carried out as directly as possible and can be established vertically as well as horizontally. Connection of the chimney must be carried out using a wall lining in the brickwork, or arranged according to the specifications of the flue manufacturer. Connecting pieces for house chimneys are made to shape from fire-clay or steel piping (2 mm sheet steel according to DIN 1623, DIN 1298 and DIN EN 1856 is normally used).

NOTE

Requirements to the connecting piece in accordance with DIN 18160 Part 2.

6.5 HEAT DISSIPATION

Since it is possible to use different fireplace types with our fireplace inserts, it is essential to consult a professional company when planning a fireplace. Make sure that the level of heat dissipation is sufficient. This can be achieved by using convection air ducts in the cladding, via heat-dissipating cladding elements or using a combination of both.

6.5.1 HOT AIR SYSTEMS

Fireplace systems designed to transfer heat generated by convection (stoves, fireplaces, etc.) must comply with the following points:

- The cross-section for the air inlet opening and for the air outlet opening must be obtained from the technical data. Deviating cross-sections are possible on calculated verification.
- It must not be possible to close at least 50% of the air inlet and air outlet openings.
- Convection air jackets must be attached at all four connecting stubs. It must not be possible to close the air inlet and air outlet openings.
- Air circuit pipes must be manufactured from a non-flammable, non-deformable material.
- No flammable objects or materials (wooden ceiling components, furniture) may be positioned within an area 30 cm to the side of, and 50 cm above the system hot air discharge grilles.

6.5.2 FIREPLACE SYSTEMS WITH HEATING GAS LINES PREPARED BY A CRAFTSMAN

Spartherm fireplace inserts that are tested according to EN 13229 are suitable for the attachment of ceramic gas lines prepared by craftsmen. The dimensioning and the layout of the ceramic heating gas lines prepared by a craftsman must be carried out according to applicable set of rules.

Verification must be provided that the heating gas temperature can sufficiently operate the chimney system after leaving the ceramic line and that the fireplace system has a sufficiently dimensioned heating-up unit cross-section.

The stove fitter must inform the operator about the mode of operation and the correct handling of the fireplace system.

6.5.3 CLOSED FIREPLACE SYSTEM CASING

Systems, in which heat dissipation is transmitted across the external surfaces of the fireplace (stoves, hypo-caustic units, devices with closeable convection air openings, etc.), i.e. to the surroundings via radiation from the casing surfaces, must comply with the following:

- The fireplace system must be designed and installed in accordance with KL industry specifications (TR OL 2006).
- We recommend the use of sufficient storage material (e.g. Magnetherm), in order to guarantee optimal heating and prevent over-heating due to temperature peaks.
- Stove dimensions, i.e. the size of the heat-transmitting surfaces, will be dependent on thermal output and heating requirements!
- Fireplace casing components must be selected to meet the heightened requirements.
- The installer is obliged to inform the operator (preferably in writing) of

any special constructional or operating features. The amount of wood used must correspond to the heat-transmitting properties of the surface and the storage capacity of the storage medium (as a general rule, the fire should not need refuelling more than 2 - 3 times per day).

- It is recommended, that contacting surfaces manufactured from flammable substances be protected by ventilation.
- In systems fitted with sliding firebox doors, the guide roller and bearing temperature must not exceed 270°C. Wherever possible, the area around the fireplace insert should be insulated separately by means of moveable mechanical components.
- When fitting components, ensure that the manufacturer's installation guidelines are strictly adhered to, especially in respect of allowable operating or ambient temperature and (wherever possible) accessibility.

7. GENERAL INSTALLATION INSTRUCTIONS FOR INSTALLATION SPACES MADE FROM NON-COMBUSTIBLE CONSTRUCTION MATERIALS

Important note: fireplace inserts must not be mounted on floating floor screed, these must be mounted on composite screed with sufficient load-bearing capacity. There must be a cleaning opening for the exhaust pipe in the chimney cladding and with the respective products, water, heating and power connections must be provided!

7.1 FLOORS AND ATTACHMENT WALLS

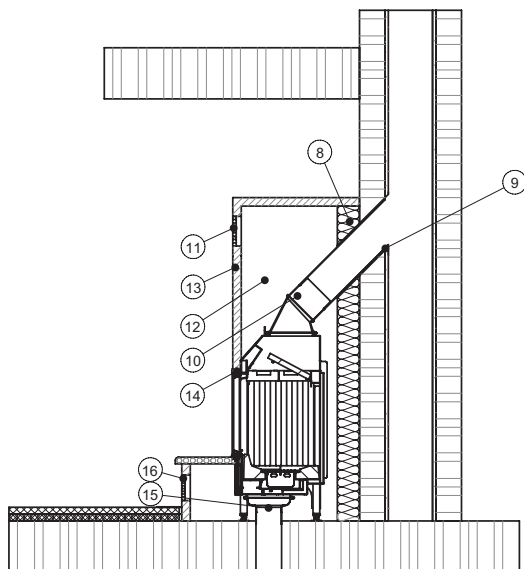

The figure shows the installation situation using the Varia 1V-51-4S as an example and applies as an example for all fireplace inserts.

- 8 Insulation of the heating chamber according to the heat insulation technical data.
- 9 If necessary, wall sleeve with sealing cord
- 10 Exhaust pipe (connecting piece)
- 11 Supply air grille (hot air outlet) The position must be selected in such a manner, that a distance of 500 mm is between the top edge of the grille and the ceiling..
- 12 Heating chamber
- 13 Chimney system cladding made from non-combustible construction material
- 14 Mounting frame with insulation strips
- 15 Separate combustion air connection
- 16 Air circulation grille (cold air supply)

7.2 FLOORS, ATTACHMENT WALLS AND CEILING

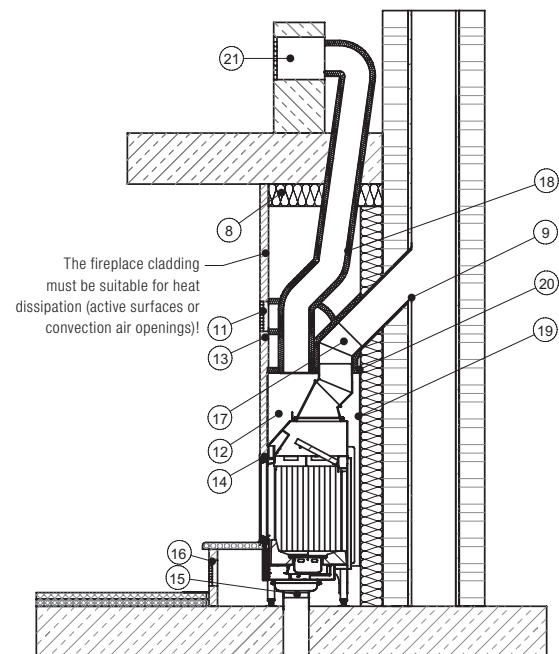

The fireplace cladding must be suitable for heat dissipation (active surfaces or convection air openings)!

The figure shows the installation situation using the Varia 1V-51-4S as an example and applies as an example for all fireplace inserts.

- 8 Insulation of the heating chamber all-round according to the heat insulation technical data.
- 9 If necessary, wall sleeve with sealing cord
- 11 Supply air grille (hot air outlet) The position must be selected in such a manner, that a distance of 500 mm is between the top edge of the grille and the ceiling.
- 12 Heating chamber
- 13 Chimney cladding made from non-combustible construction material
- 14 Mounting frame with insulation strips
- 15 Separate combustion air connection
- 16 Air circulation grille (cold air supply)
- 17 Insulated flue gas pipe (connecting piece) with at least 3 cm thick dimensionally stable mineral wool
- 18 Insulation of the connecting lines with at least 3 cm thick dimensionally stable mineral wool
- 19 Convection air housing
- 20 Top insulation of the convection air housing min. 3 cm
- 21 Observe the air return!

8. GENERAL INSTALLATION INSTRUCTIONS FOR INSTALLATION SPACES MADE FROM COMBUSTIBLE CONSTRUCTION MATERIALS

8.1 FLOORS, ATTACHMENT WALLS AND CEILING

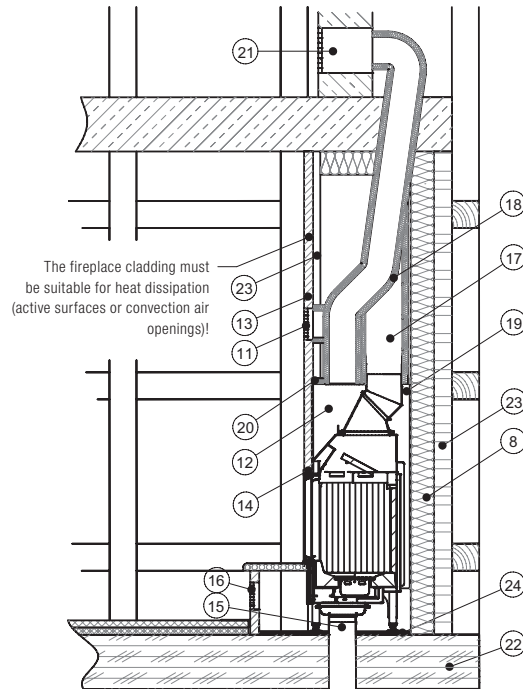

8 Insulation of the heating chamber using, e.g., dimensionally stable mineral wool according to the heat insulation thickness technical data.

11 Supply air grille (hot air outlet) The position must be selected in such a manner, that a distance of 500 mm is between the top edge of the grille and the ceiling.

12 Heating chamber

13 Chimney cladding made from non-combustible construction material

14 Mounting frame with insulation strips

15 Separate combustion air connection

16 Air circulation grille (cold air supply)

17 Insulated flue gas pipe (connecting piece) with at least 3 cm thick dimensionally stable mineral wool

18 Insulation of the connecting lines with at least 3 cm thick dimensionally stable mineral wool

19 Convection air housing made of steel plate

20 Top insulation of the convection air housing min. 3 cm

21 Observe the air return!

22 Combustible construction material (wooden floor)

23 Stud wall, 10 cm thick*

24 Floor protection covering within the heating chamber made from non-combustible material as long as no insulation is necessary according to the heat insulation thickness of the technical data!

* If necessary, use a substitute insulation material (e.g. calcium silicate) in the place of front-mounted masonry and insulation (point 8), in accordance with the technical data provided by the manufacturer.

The figure shows the installation situation using the Varia 1V-51-4S with convection air housing as an example and applies as an example for all fireplace inserts.

8.2 INSULATION

Special measures for fire protection with combustible construction materials (flooring and / or mounting walls) relating to the insulation.

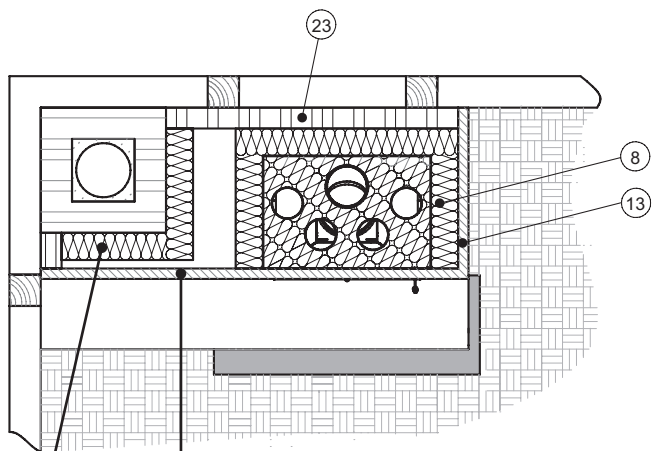

The figure shows the installation situation using the Varia 1V-51-4S with convection air housing as an example and applies as an example for all fireplace inserts.

If and how the chimney walls in your installation situation have to be insulated, please consult your responsible stove fitter and the chimney sweeper.

The fireplace cladding must be 17 suitable for heat dissipation (active surfaces or convection air openings)!

8 Insulation of the convection air housing all-around using, e.g., dimensionally stable mineral wool according to the heat insulation thickness technical data.

13 Chimney cladding made from non-combustible construction material

23 Stud wall, 10 cm thick*

* If necessary, use a substitute insulation material (e.g. calcium silicate) in the place of front-mounted masonry and insulation (point 8), in accordance with the technical data provided by the manufacturer.

9. CLEANING THE FIREPLACE SYSTEMS

Fireplace systems must be designed in such a manner that the air inlets and air outlets can easily be cleaned and the distance area to the ceiling, the walls and built-in furniture can be viewed easily and kept free. The service openings must always be installed easy to access so that cleaning is not made difficult.

10. SPECIAL INFORMATION FOR SPARTHERM FIREPLACE INSERTS

10.1 FLUE GAS OUTLET

The flue gas outlet can be turned. It can be connected to the chimney vertically as well as horizontally. For connecting to the side, there is a 90° flue gas dome for the favourable flow connection of the 0° flue gas dome available in the delivery program.

10.2 FIREPLACE INSERT WITH PUSH-UP COMBUSTION CHAMBER DOOR

Completely remove the transport safety device before installing. Check the function of the push-up combustion chamber door in all cases before the cladding is mounted on the fireplace insert.



10.3 CARRYING AIDS

Certain fireplace inserts are prepared for the use of carrying aids.

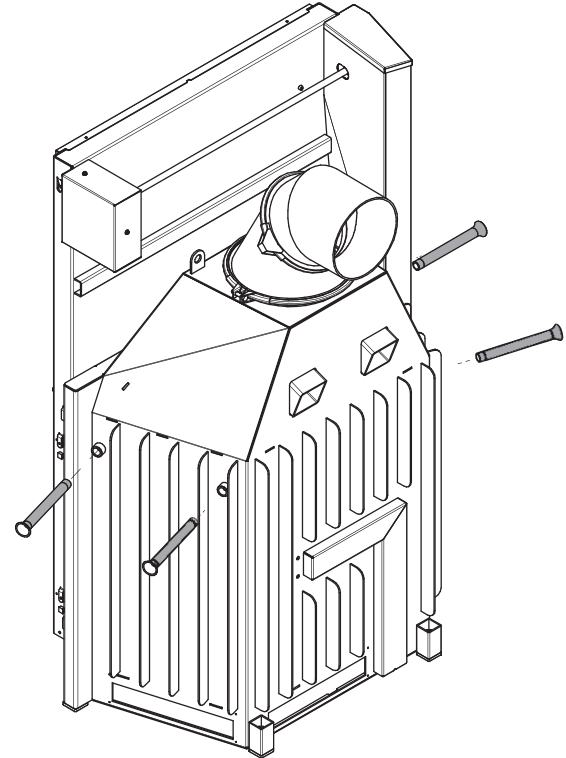

11. TECHNICAL DATA

		Mini R1V51	Mini R1V 57	Mini R1V 51 NSHF	Mini R1V 57 NSHF	Mini R1Vh 57	Mini R1Vh 57 NSHF	Mini Z1	Mini Z1 NSHF
General data	Nominal heat output kW (closed operation)	5.2	5.0	6.2	6.2	5.0	6.2	7.0	10.0
	Thermal output range kW	4.5-6,8	4.5-6,5	4.5-8,1	4.5-8,1	4.5-6,5	4.5-8,1	4.9-9,1	7.0-13,0
	Efficiency %	80	> 80	> 80	> 80	> 80	> 80	>78	>80
	Required chimney diameter (mm)	160	160	160	160	160	160	180	180
	Flue gas connection: Ø mm	160	160	160	160	160	160	180	180
	Possible flue gas connection Ø mm	-	-	-	-	-	-	-	-
	Weight (approx.) kg	125	126	125	126	150	150	160	160
	Required minimum cross-section for supply and recirculating air (with WLM) cm ²	700	700	700	700	700	700	700	-
Required minimum cross-section for recirculating and supply air (without WLM) cm ²	650/780	650/780	930/970	650/780	650/780	650/780	950/1140	1360/1640	
Testing and values	non-self-closing combustion chamber door (Design A)	✓	✓	✓	✓	✓	✓	✓	-
	self-closing combustion chamber door (Design A1)	✓	✓	✓	✓	✓	✓	✓	✓
	Operation with open combustion chamber door	-	-	-	-	-	-	✓	-
	Level 2 BlmSchV [Ordinance in the Implementation of the Federal Immission Control Act]	✓	✓	✓	✓	✓	✓	✓	✓
	15a BVG	✓	✓	✓	✓	✓	✓	✓	✓
Operation with open combustion chamber (multiple allocation not permitted)	Mass flow of flue gas g/s	-	-	-	-	-	-	20.9	-
	Flue gas temperature °C	-	-	-	-	-	-	240	-
	Flue gas temperature behind the NSHF °C	-	-	-	-	-	-	-	-
	Combustion air requirement m ³ /h	-	-	-	-	-	-	68.7	-
	Required supply pressure: in Pa	-	-	-	-	-	-	12	-
Operation with closed combustion chamber (multiple allocation permitted)	Mass flow of flue gas g/s	4.7	4.0	6.0	5.0	4.0	5.0	7.5	7.6
	Flue gas temperature °C (on the flue gas outlet)	255	258	355 (164 behind NSHF)	355 (193 behind NSHF)	258	355 (193 behind NSHF)	330	470 (240 behind NSHF)
	Required supply pressure: in Pa	12	12	12	12	12	12	14	14
	CO ₂ %	9.8	11.3	8.0	10.0	11.3	10.0	8.6	11.1
	Required diameter after M-FeuVo. cm	15	15	15	15	15	15	15	15
	Combustion air requirement m ³ /h	16.2	13.4	21.4	17.2	13.4	17.2	25.5	25.2
Heating chamber distance	to the heating chamber wall cm	9	9	11	11	9	11	10	10
	To the setup floor cm	0	0	0	0	0	0	0	0
Heat insulation (example rock wool matting to AGI-Q 132)	Setup floor cm	0	0	0	0	0	0	0	0
	Mounting wall cm	12	12	12	12	12	12	8	8
	Side wall cm	12	12	12	12	12	12	8	8
	Stud wall with a wall that must be protected cm	10	10	10	10	10	10	10	10
Substitute insulation material, calcium silicate	Setup floor cm	0	0	0	0	0	0	0	0
	Mounting wall cm	9	9	9	9	9	9	6	6
	Side wall cm	9	9	9	9	9	9	6	6
Heat distribution	Convection %	62	60	62	60	60	60	68	74
	Viewing panel %	38	40	38	40	40	40	32	26
	H ₂ O %	0	0	0	0	0	0	0	0

Changes and mistakes reserved

* Fulfills 15a 2015 only with AT hand piece, attention: flue gas connection + 160 mm

*** Values were not available at the time of printing.

*** Deviating insulation guidelines apply for GET fireplace inserts. This can be obtained from the separate GET manual.

11. TECHNICAL DATA

	Mini S	Mini Sh	Speedy 1V 51	Speedy 1V 57	Speedy 1V 51 NSHF	Speedy 1V 57 NSHF	Speedy 1V 51 (Export)	Speedy 1V 57 (Export)	
General data	Nominal heat output kW (closed operation)	7.0	7.0	9.0	9.0	10.0	10.0	14.5	14.5
	Thermal output range kW	4.9-9,1	4.9-9,1	6.3-11,7	6.3-11,7	7.0-13,0	7.0-13,0	10.2-18,9	10.2-18,9
	Efficiency %	>78	>78	80	80	> 80	> 80	> 78	>78
	Required chimney diameter (mm)	180	180	200	200	200	200	200	200
	Flue gas connection: Ø mm	180	180	200	200	200	200	200	200
	Possible flue gas connection Ø mm	-	-	180	180	180	180	180	180
	Weight (approx.) kg	205	205	195	200	195	200	195	200
	Required minimum cross-section for supply and recirculating air (with WLM) cm ²	700	700	700	700	700	-	700	700
Required minimum cross-section for recirculating and supply air (without WLM) cm ²	810/890	810/890	1420/1710	1420/1710	1420/1710	1420/1710	1420/1710	1420/1710	
Testing and values	non-self-closing combustion chamber door (Design A)	✓	✓	✓	✓	✓	-	✓	✓
	self-closing combustion chamber door (Design A1)	✓	✓	✓	✓	✓	✓	✓	✓
	Operation with open combustion chamber door	✓	✓	-	-	-	-	-	-
	Level 2 BImSchV (Ordinance in the Implementation of the Federal Immission Control Act)	✓	✓	✓	✓	✓	✓	✓	✓
	15a BVG	✓*	✓*	✓	✓	✓	✓	✓*	✓*
Operation with open combustion chamber (multiple allocation not permitted)	Mass flow of flue gas g/s	17.8	17.8	-	-	-	-	-	-
	Flue gas temperature °C	230	230	-	-	-	-	-	-
	Flue gas temperature behind the NSHF °C	-	-	-	-	-	-	-	-
	Combustion air requirement m ³ /h	86.4	85.5	-	-	-	-	-	-
	Required supply pressure: in Pa	12	12	-	-	-	-	-	-
Operation with closed combustion chamber (multiple allocation permitted)	Mass flow of flue gas g/s	8.8	8.8	7.2	7.5	9.3	8.8	10.9	10.2
	Flue gas temperature °C (on the flue gas outlet)	290	290	342	299	391 <small>(163 behind NSHF)</small>	392 <small>(170 behind NSHF)</small>	346	327
	Required supply pressure: in Pa	14	14	12	12	12	12	12	12
	CO ₂ %	7.9	7.9	12.2	11.7	9.4	10.0	12.2	13.2
	Required diameter after M-FeuVo. cm	15	15	15	15	15	15	15	15
	Combustion air requirement m ³ /h	27.6	27.6	21.1	23.4	29.8	27.7	36.8	34.0
Heating chamber distance	to the heating chamber wall cm	9	9	10	10	10	10	10	10
	To the setup floor cm	0	0	0	0	0	0	0	0
Heat insulation (example rock wool matting to AGI-Q 132)	Setup floor cm	0	0	0	0	0	0	0	0
	Mounting wall cm	9	8	16	16	16	16	16	16
	Side wall cm	9	8	16	16	16	16	16	16
	Stud wall with a wall that must be protected cm	10	10	10	10	10	10	10	10
Substitute insulation material, calcium silicate	Setup floor cm	0	0	0	0	0	0	0	0
	Mounting wall cm	7	6	12	12	12	12	12	12
	Side wall cm	7	6	12	12	12	12	12	12
Heat distribution	Convection %	58	58	64	64	64	62	64	62
	Viewing panel %	42	42	36	36	36	38	36	38
	H ₂ O %	0	0	0	0	0	0	0	0

Changes and mistakes reserved

* Fulfills 15a 2015 only with AT hand piece, attention: flue gas connection + 160 mm

GB 26

*** Values were not available at the time of printing.

*** Deviating insulation guidelines apply for GET fireplace inserts. This can be obtained from the separate GET manual.

Speedy Kh	Speedy 1Vh 57	Speedy 1Vh 51 NSHF	Speedy 1Vh 57 NSHF	Speedy 1Vh 51 (Export)	Speedy 1Vh 57 (Export)	Varia 1V 51	Varia 1V 57	Varia 1V S	Varia 1V 51 (Export)	Varia 1V 57 (Export)	Varia 1Vh 45	Varia 1Vh 51	Varia 1Vh 57
9.0	9.0	10.0	10.0	14.5	14.5	11.0	11.0	7.0	17.5	17.5	11.0	11.0	11.0
6.3-11,7	6.3-11,7	7.0-13,0	7.0-13,0	10.2-18,9	10.2-18,9	7.7-14,3	7.7-14,3	4.9-9,1	12.3-21,2	12.3-21,2	7.7-14,3	7.7-14,3	7.7-14,3
80	80	> 80	> 80	> 78	>78	>80	>80	> 80	>78	>78	>78	>80	>80
200	200	200	200	200	200	200	200	200	200	200	200	200	200
200	200	200	200	200	200	200	200	200	200	200	200	200	200
180	180	180	180	180	180	180	180	180	180	180	180	180	180
200	235	200	235	200	200	200	205	200	200	205	220	245	268
700	700	700	-	700	700	700	700	700	700	700	700	700	700
1420/1710	1420/1710	1420/1710	1420/1710	1420/1710	1420/1710	1420/1710	1420/1710	900/1090	1420/1710	1420/1710	1420/1710	1420/1710	1420/1710
✓	✓	✓	-	✓	✓	✓	✓	✓	✓	✓	✓	✓	✓
✓	✓	✓	✓	✓	✓	✓	✓	✓	✓	✓	✓	✓	✓
-	-	-	-	-	-	-	-	-	-	-	✓	-	-
✓	✓	✓	✓	✓	✓	✓	✓	✓	✓	✓	✓	✓	✓
✓	✓	✓	✓	✓*	✓*	-	✓	✓	-	✓*	✓	-	✓
-	-	-	-	-	-	-	-	-	-	-	43.1	-	-
-	-	-	-	-	-	-	-	-	-	-	236	-	-
-	-	-	-	-	-	-	-	-	-	-	-	-	-
-	-	-	-	-	-	-	-	-	-	-	93.7	-	-
-	-	-	-	-	-	-	-	-	-	-	8	-	-
7.2	7.5	9.3	8.8	10.9	10.2	9.6	9.0	5.6	13.1	13.4	10.0	9.6	9.0
342	299	391 (163 behind NSHF)	392 (170 behind NSHF)	346	327	288	305	300	330	333	355	288	305
12	12	12	12	12	12	12	12	12	12	12	11	12	12
12.2	11.7	9.4	10.0	12.2	13.2	10.9	11.8	10.3	12.2	12.1	9.5	10.9	11.8
15	15	15	15	15	15	15	15	15	15	15	15	15	15
21.6	23.4	29.8	27.7	36.8	34.0	36.1	36.1	19.9	44.7	45.3	36.1	36.1	36.1
10	10	10	10	10	10	10	10	7	10	10	12	10	10
0	0	0	0	0	0	0	0	0	0	0	0	0	0
0	0	0	0	0	0	0	0	0	0	0	0	0	0
16	16	16	16	16	16	13	11	13	13	11	13	13	11
16	16	16	16	16	16	13	13	13	13	13	13	13	13
10	10	10	10	10	10	10	10	10	10	10	10	10	10
0	0	0	0	0	0	0	0	0	0	0	0	0	0
12	12	12	12	12	12	10	9	10	10	9	10	10	9
12	12	12	12	12	12	10	10	10	10	10	10	10	10
64	62	64	62	64	62	65	62	65	65	62	65	65	62
36	38	36	38	36	38	35	38	35	35	38	35	35	38
0	0	0	0	0	0	0	0	0	0	0	0	0	0

Changes and mistakes reserved

* Fulfills 15a 2015 only with AT hand piece, attention: flue gas connection + 160 mm

GB 27

*** Values were not available at the time of printing.

*** Deviating insulation guidelines apply for GET fireplace inserts.
This can be obtained from the separate GET manual.

11. TECHNICAL DATA

	Varia 1Vh S	Varia 1Vh 51 (Export)	Varia 1Vh 57 (Export)	Varia 1V 100h	Varia 1V 100h (Export)	Varia Sh	Varia SRh	Varia AS-2	
General data	Nominal heat output kW (closed operation)	7.0	17.5	17.5	10.4	17.0	11.0	11.0	7.0
	Thermal output range kW	4.9-9,1	12,3-21,2	12,3-21,2	7,3-13,5	11,9-21,2	7,7-14,3	7,7-14,3	4,9-9,1
	Efficiency %	> 80	>78	>78	80	80	80	>78	> 80
	Required chimney diameter (mm)	200	200	200	250	250	200	200	180
	Flue gas connection: Ø mm	200	200	200	250	250	200	200	180
	Possible flue gas connection Ø mm	180	180	180	200	200	180	180	-
	Weight (approx.) kg	245	268	268	351	351	300	300	171
	Required minimum cross-section for supply and recirculating air (with WLM) cm ²	700	700	700	700	700	700	700	700
Required minimum cross-section for recirculating and supply air (without WLM) cm ²	900/1090	1420/1710	1420/1710	1200/1500	1200/1500	1250/1500	1300/1560	1000/1200	
Testing and values	non-self-closing combustion chamber door (Design A)	✓	✓	✓	✓	✓	✓	✓	✓
	self-closing combustion chamber door (Design A1)	✓	✓	✓	✓	✓	✓	✓	✓
	Operation with open combustion chamber door	-	-	-	-	-	-	✓	-
	Level 2 BImSchV (Ordinance in the Implementation of the Federal Immission Control Act)	✓	✓	✓	✓	✓	✓	-	✓
	15a BVG	✓	-	✓*	✓	✓	✓	✓*	✓
Operation with open combustion chamber (multiple allocation not permitted)	Mass flow of flue gas g/s	-	-	-	-	-	-	22.1	-
	Flue gas temperature °C	-	-	-	-	-	-	270	-
	Flue gas temperature behind the NSHF °C	-	-	-	-	-	-	-	-
	Combustion air requirement m ³ /h	-	-	-	-	-	-	126.1	-
	Required supply pressure: in Pa	-	-	-	-	-	-	10	-
Operation with closed combustion chamber (multiple allocation permitted)	Mass flow of flue gas g/s	5.6	13.1	13.4	11.4	15.9	9.5	10.0	7.0
	Flue gas temperature °C (on the flue gas outlet)	300	330	333	275	319	300	330	275
	Required supply pressure: in Pa	12	12	12	12	13	11	12	12
	CO ₂ %	10.3	12.2	12.1	7.9	9.3	10.1	9.6	8.4
	Required diameter after M-FeuVo. cm	15	15	15	15	15	15	15	15
Combustion air requirement m ³ /h	19.9	44.7	45.3	40	55.7	33.1	35.6	24.9	
Heating chamber distance	to the heating chamber wall cm	7	10	10	Side: 10 Back: 20	Side: 10 Back: 20	12	11	10
	To the setup floor cm	0	0	0	0	0	0	0	0
Heat insulation (example rock wool matting to AGI-Q 132)	Setup floor cm	0	0	0	0	0	0	0	0
	Mounting wall cm	13	13	11	12	12	11	8	13
	Side wall cm	13	13	13	12	12	9	8	13
	Stud wall with a wall that must be protected cm	10	10	10	10	10	10	10	10
Substitute insulation material, calcium silicate	Setup floor cm	0	0	0	0	0	0	0	0
	Mounting wall cm	10	10	9	9	9	9	6	10
	Side wall cm	10	10	10	9	9	7	6	10
Heat distribution	Convection %	65	65	62	61	61	57	58	59
	Viewing panel %	35	35	38	39	39	43	42	41
	H ₂ O %	0	0	0	0	0	0	0	0

Changes and mistakes reserved

* Fulfills 15a 2015 only with AT hand piece, attention: flue gas connection + 160 mm

GB 28

*** Values were not available at the time of printing.

*** Deviating insulation guidelines apply for GET fireplace inserts. This can be obtained from the separate GET manual.

Varia AS-2 NSHF	Varia AS-2 (Export)	Varia ASH-2	Varia ASH-2 NSHF	Varia ASH-2 (Export)	Varia Ah	Varia Ah-2	Varia Bh	Varia Bh S	Varia B-120h	Varia M-60h	Varia M-80h	Varia M-100h	Varia M-60h GET
11.0	11.0	7.0	11.0	11.0	10.4	9.0	10.4	9.0	15.0	7.0	9.0	11.0	8.0
7.7 - 14.3	7.7 - 14.3	4.9-9,1	7.7 - 14.3	7.7 - 14.3	7.3-13,5	6.3-11,7	7.3-13,5	6.3-11,7	10.5-19,5	4.9-9,1	6.3-11,7	7.7-14,3	5.6-10,4
> 80	> 80	> 80	> 80	> 80	> 80	> 80	>78	>78	>78	>78	>78	>78	80
180	180	180	180	180	200	200	250	250	250	200	200	200	180
180	180	180	180	180	200	200	250	250	250	200	200	200	180
-	-	-	-	-	180	180	-	-	200	180	180	180	-
171	171	212	212	212	300	300	350	350	370	205	300	350	205
700	700	700	700	700	700	700	700	700	700	700	700	700	-
1000/1200	1000/1200	1000/1200	1000/1200	1000/1200	1410/1690	990/1190	1270/1520	1270/1520	1600/1910	870/1050	1090/1310	1300/1560	930/1250
✓	✓	✓	✓	✓	✓	✓	✓	✓	-	✓	✓	✓	-
✓	✓	✓	✓	✓	✓	✓	✓	✓	✓	✓	✓	✓	✓
-	-	-	-	-	✓	✓	-	-	-	✓	✓	✓	-
✓	✓	✓	✓	✓	✓	✓	✓	✓	✓	✓	✓	-	✓
✓	✓	✓	✓	✓	✓	-	✓*	✓*	✓*	✓*	✓*	✓*	✓
-	-	-	-	-	36.2	13.7	-	-	-	22.8	21.7	45.8	-
-	-	-	-	-	260	268	-	-	-	250	230	320	-
-	-	-	-	-	-	-	-	-	-	-	-	-	-
-	-	-	-	-	126.2	126.2	-	-	-	85.8	115.6	145.5	-
-	-	-	-	-	12	12	-	-	-	10	10	10	-
9.6	9.5	7.0	9.6	9.5	8.5	9.0	9.5	8.5	15.4	6.8	9.1	11.9	7.3
³⁴⁷ (197 behind NSHF)	340	275	³⁴⁷ (197 behind NSHF)	340	310	267	311	278	296	330	310	340	311
12	12	12	12	12	12	12	12	12	12	12	12	14	12
8.8	9.5	8.4	8.8	9.5	11.1	9.0	10.3	9.7	8.9	9.9	8.9	8.5	9.3
15	15	15	15	15	15	15	15	15	2x15	15	15	15	15
35.1	35.4	24.9	35.1	35.4	28.5	30.1	31.4	28.7	52.5	22.1	31.6	40.0	26.2
10	10	10	10	10	8	8	6	6	10	7	8	9	6
0	0	0	0	0	0	0	0	0	0	0	0	0	0
0	0	0	0	0	0	0	0	0	12	0	0	0	***
13	13	13	13	13	13	13	13	13	16	10	10	9	*** 11
13	13	13	13	13	13	11	9	9	16	10	10	9	*** 6
10	10	10	10	10	10	10	10	10	10	10	10	10	***
0	0	0	0	0	0	0	0	0	0	0	0	0	***
10	10	10	10	10	10	10	10	10	12	8	8	7	***9
10	10	10	10	10	10	9	7	7	12	8	8	7	***5
64	59	59	64	59	64	55	53	66	53	62	60	59	57
36	41	41	36	41	36	45	47	34	47	38	40	41	43
0	0	0	0	0	0	0	0	0	0	0	0	0	0

Changes and mistakes reserved

* Fulfills 15a 2015 only with AT hand piece, attention: flue gas connection + 160 mm

*** Values were not available at the time of printing.

*** Deviating insulation guidelines apply for GET fireproof inserts. This can be obtained from the separate GET manual.

11. TECHNICAL DATA

	Varia M-60h GET+DH	Varia M-80h GET	Varia M-80h GET + DH	Varia M-100h GET	Varia M-100h GET + DH	Arte 1Vh	Arte 1Vh-66	Arte 1Vh-66 mit NSHF	
General data	Nominal heat output kW (closed operation)	8.0	9.0	9.0	10.4	10.4	8.0	6.4	10.4
	Thermal output range kW	5.6-10,4	6.3-11,7	6.3-11,7	7.4-13,5	7.4-13,5	5.6-10,4	4.5-8,3	7.3-13,5
	Efficiency %	80	> 80	> 80	80	80	>80	>80	>80
	Required chimney diameter (mm)	180	180	180	180	180	180	180	180
	Flue gas connection: Ø mm	180	180	180	180	180	180	180	180
	Possible flue gas connection Ø mm	-	-	-	-	-	-	-	-
	Weight (approx.) kg	235	250	280	300	340	180	240	240
	Required minimum cross-section for supply and recirculating air (with WLM) cm ²	-	-	-	-	-	700	700	-
Required minimum cross-section for recirculating and supply air (without WLM) cm ²	930/1250	860/1140	860/1140	860/1415	860/1415	1030/1240	570/770	570/770	
Testing and values	non-self-closing combustion chamber door (Design A)	-	✓	✓	✓	✓	✓	✓	✓
	self-closing combustion chamber door (Design A1)	✓	✓	✓	✓	✓	✓	✓	✓
	Operation with open combustion chamber door	-	-	-	-	-	-	-	-
	Level 2 BImSchV (Ordinance in the Implementation of the Federal Immission Control Act)	✓	✓	✓	✓	✓	✓	✓	✓
	15a BVG	✓	✓	✓	✓	✓	✓	✓	✓
Operation with open combustion chamber (multiple allocation not permitted)	Mass flow of flue gas g/s	-	-	-	-	-	18.9	-	-
	Flue gas temperature °C	-	-	-	-	-	230	-	-
	Flue gas temperature behind the NSHF °C	-	-	-	-	-	-	-	-
	Combustion air requirement m ³ /h	-	-	-	-	-	93.4	-	-
	Required supply pressure: in Pa	-	-	-	-	-	10	-	-
Operation with closed combustion chamber (multiple allocation permitted)	Mass flow of flue gas g/s	7.3	7.0	7.0	8.7	8.7	7.1	5.0	**
	Flue gas temperature °C (on the flue gas outlet)	311	279	279	308	308	300	241	**
	Required supply pressure: in Pa	12	12	12	12	12	12	12	**
	CO ₂ %	9.3	11.4	11.4	11.0	11.0	9.9	**	**
	Required diameter after M-FeuVo. cm	15	15	15	15	15	15	**	**
Combustion air requirement m ³ /h	26.2	23.7	23.7	28.8	28.8	24.3	**	**	
Heating chamber distance	to the heating chamber wall cm	6	6	6	6	6	9	**	**
	To the setup floor cm	0	0	0	0	0	0	**	**
Heat insulation (example rock wool matting to AGI-Q 132)	Setup floor cm	0	***	0	***	0	0	**	**
	Mounting wall cm	0	*** 13	0	*** 13	0	8	**	**
	Side wall cm	0	*** 9	0	*** 9	0	8	**	**
	Stud wall with a wall that must be protected cm	0	***	0	***	0	10	**	**
Substitute insulation material, calcium silicate	Setup floor cm	0	***	0	***	0	0	**	**
	Mounting wall cm	0	***10	0	***10	0	6	**	**
	Side wall cm	0	***7	0	***7	0	6	**	**
Heat distribution	Convection %	57	53	53	51	51	65	76	76
	Viewing panel %	43	47	47	49	49	35	24	24
	H ₂ O %	0	0	0	0	0	0	0	0

Changes and mistakes reserved

* Fulfills 15a 2015 only with AT hand piece, attention: flue gas connection + 160 mm

*** Values were not available at the time of printing.

*** Deviating insulation guidelines apply for GET fireplace inserts. This can be obtained from the separate GET manual.

Arte 1Vh-66 (Export)	Arte F-1V	Arte F-1V NSHF	Arte F-1V (Export)	Arte F-1Vh	Arte F-1Vh NSHF	Arte F-1Vh (Export)	Arte Bh	Arte Xh	Mini S-FDh	Varia FD	Varia FDh	Varia AS-FD-2	Varia AS-FD-2 NSHF
14.0	5.9	9.4	9.4	5.9	9.4	9.4	11.0	11.0	6.0	11.0	11.0	7.0	11.0
9.8-18,2	4.5-7,7	6.6-12,2	6.6-12,2	4.5-7,7	6.6-12,2	6.6-12,2	7.7-14,3	7.7-14,3	4.5-7,8	7.7-14,3	7.7-14,3	4.9-9,1	7.7 - 14.3
>80	> 80	> 80	80	> 80	> 80	80	>78	>78	>78	>78	>78	> 80	>80
180	160	160	160	160	160	160	200	250	200	250	250	180	180
180	160	160	160	160	160	160	200	250	200	250	250	180	180
-	-	-	-	-	-	-	180	-	180	-	-	-	-
240	86	86	86	100	100	100	260	422	180	300	378	168	171
700	-	-	-	-	-	-	700	700	700	700	700	700	700
570/770	260/300	350/400	260/300	260/300	260/300	260/300	1230/1480	1320/1580	640/770	1110/1340	1110/1340	800/1000	800/1000
✓	✓	✓	✓	✓	✓	✓	✓	✓	✓	✓	✓	✓	✓
✓	✓	✓	✓	✓	✓	✓	✓	✓	✓	✓	✓	✓	✓
-	-	-	-	-	-	-	✓	✓	✓	✓	✓	-	-
✓	✓	✓	✓	✓	✓	✓	✓	✓	✓	✓	✓	✓	✓
✓	✓	✓	✓	✓	✓	✓	✓*	✓*	✓*	-	-	✓	✓
-	-	-	-	-	-	-	22.4	28.5	23.8	43.1	43.1	-	-
-	-	-	-	-	-	-	260	250	280	236	236	-	-
-	-	-	-	-	-	-	-	-	-	-	-	-	-
-	-	-	-	-	-	-	151.3	195.3	171.5	214.4	214.4	-	-
-	-	-	-	-	-	-	10	10	9	8	8	-	-
**	5.1	8.1	7.8	5.1	8.1	7.8	10.7	11.6	5.4	10.0	10.0	6.1	9.9
**	318	400 (194 behind NSHF)	353	318	400 (194 behind NSHF)	353	350	300	360	355	355	290	272 (142 behind NSHF)
**	12	12	12	12	12	12	12	12	12	11	11	12	12
**	10.0	10.0	10.7	10.0	10.0	10.7	9.7	8.6	10.0	9.5	9.5	9.2	8.4
**	15	15	15	15	15	15	15	15	15	15	15	15	15
**	17.8	27.6	26.8	17.8	27.6	26.8	35.2	39.8	18.7	36.1	36.1	23.2	35.3
**	10	10	10	10	10	10	11	6	7	13	13	6	6
**	0	0	0	0	0	0	0	0	0	0	0	0	0
**	0	0	0	0	0	0	0	5	4	0	0	0	0
**	11	11	11	11	11	11	11	10	0	0	0	0	0
**	11	11	11	11	11	11	11	10	11	13	13	11	11
**	10	10	10	10	10	10	10	10	10	10	10	10	10
**	0	0	0	0	0	0	0	4	3	0	0	0	0
**	9	9	9	9	9	9	9	8	0	0	0	0	0
**	9	9	9	9	9	9	9	8	9	10	10	9	9
76	75	75	75	75	75	75	56	60	53	51	51	59	59
24	25	25	25	25	25	25	44	40	47	49	49	41	41
0	0	0	0	0	0	0	0	0	0	0	0	0	0

Changes and mistakes reserved

* Fulfills 15a 2015 only with AT hand piece, attention: flue gas connection + 160 mm

*** Values were not available at the time of printing.

*** Deviating insulation guidelines apply for GET fireplace inserts. This can be obtained from the separate GET manual.

11. TECHNICAL DATA

	Varia AS-FD-2 (Export)	Varia AS-FDh-2	Varia AS-FDh-2 NSHF	Varia AS-FDh-2 (Export)	Varia A-FDh	Varia B-FDh	Arte F-FD	Arte F-FD NSHF	
General data	Nominal heat output kW (closed operation)	11.0	7.0	11.0	11.0	10.4	11.0	5.9	9.4
	Thermal output range kW	7.7 - 14.3	4.9-9,1	7.7 - 14.3	7.7 - 14.3	7.3-13,5	7.7-14,3	4.5-7,7	6.6-12,2
	Efficiency %	> 80	> 80	>80	> 80	>80	>78	> 80	> 80
	Required chimney diameter (mm)	180	180	180	180	250	250	160	160
	Flue gas connection: Ø mm	180	180	180	180	250	250	160	160
	Possible flue gas connection Ø mm	-	-	-	-	-	-	-	-
	Weight (approx.) kg	171	203	203	203	300	350	90	90
	Required minimum cross-section for supply and recirculating air (with WLM) cm ²	700	700	700	700	700	700	-	-
Required minimum cross-section for recirculating and supply air (without WLM) cm ²	800/1000	800/1000	800/1000	800/1000	1030/1240	1030/1230	400/500	400/500	
Testing and values	non-self-closing combustion chamber door (Design A)	✓	✓	✓	✓	✓	✓	✓	✓
	self-closing combustion chamber door (Design A1)	✓	✓	✓	✓	✓	✓	✓	✓
	Operation with open combustion chamber door	-	-	-	-	✓	✓	-	-
	Level 2 BImSchV (Ordinance in the Implementation of the Federal Immission Control Act)	✓	✓	✓	✓	✓	✓	✓	✓
	15a BVG	✓	✓	✓	✓	✓	✓*	✓	✓
Operation with open combustion chamber (multiple allocation not permitted)	Mass flow of flue gas g/s	-	-	-	-	21.4	23.8	-	-
	Flue gas temperature °C	-	-	-	-	240	240	-	-
	Flue gas temperature behind the NSHF °C	-	-	-	-	-	-	-	-
	Combustion air requirement m ³ /h	-	-	-	-	203.7	285	-	-
	Required supply pressure: in Pa	-	-	-	-	12	10	-	-
Operation with closed combustion chamber (multiple allocation permitted)	Mass flow of flue gas g/s	6.8	6.1	9.9	6.8	8.9	11.5	5.6	8.1
	Flue gas temperature °C (on the flue gas outlet)	320	290	272 <small>(142 behind NSHF)</small>	320	300	300	300	400 <small>(194 behind NSHF)</small>
	Required supply pressure: in Pa	12	12	12	12	12	12	12	12
	CO ₂ %	11.9	9.2	8.4	11.9	10.2	8.4	8.7	8.7
	Required diameter after M-FeuVo. cm	15	15	15	15	15	2x15	15	15
	Combustion air requirement m ³ /h	27.6	24.9	35.3	24.9	30.9	40.3	18.1	30.4
Heating chamber distance	to the heating chamber wall cm	6	10	10	10	8	11	10	10
	To the setup floor cm	0	0	0	0	0	0	0	0
Heat insulation (example rock wool matting to AGI-Q 132)	Setup floor cm	0	0	0	0	0	4	0	0
	Mounting wall cm	0	0	0	0	0	0	0	0
	Side wall cm	11	11	11	11	11	11	11	11
	Stud wall with a wall that must be protected cm	10	10	10	10	10	10	10	10
Substitute insulation material, calcium silicate	Setup floor cm	0	0	0	0	0	3	0	0
	Mounting wall cm	0	0	0	0	0	0	0	0
	Side wall cm	9	9	9	9	9	9	9	9
Heat distribution	Convection %	59	59	59	59	47	47	61	61
	Viewing panel %	41	41	41	41	53	53	39	39
	H ₂ O %	0	0	0	0	0	0	0	0

Changes and mistakes reserved

* Fulfills 15a 2015 only with AT hand piece, attention: flue gas connection + 160 mm

*** Values were not available at the time of printing.

*** Deviating insulation guidelines apply for GET fireplace inserts. This can be obtained from the separate GET manual.

Arte F-FD (Export)	Arte F-FDh	Arte F-FDh NSHF	Arte F-FDh (Export)	Arte X-FDh	Mini 2L / 2R	Mini 2L / 2R (Export)	Mini 2LRh	Mini 2LRh (Export)	Varia 2L-55 / 2R-55	Varia 2L-55h / 2R-55h	Varia 2L / 2R	Varia 2L / 2R S	Varia 2L / 2R NSHF
9.4	5.9	9.4	9.4	11.0	7.0	11.0	7.0	11.0	7.0	7.0	11.0	7.0	12.0
6.6-12,2	4.5-7,7	6.6-12,2	6.6-12,2	7.7-14,3	4.9-9,1	7.7-14,3	4.9-9,1	7.7-14,3	4.9-9,1	4.9-9,1	7.7-14,3	4.9-9,1	8.4-15,6
> 80	> 80	> 80	> 80	>78	>80	77	>80	77	> 80	> 80	80	> 78	80
160	160	160	160	300	180	180	180	180	180	180	200	200	200
160	160	160	160	300	180	180	180	180	180	180	200	200	200
-	-	-	-	-	-	-	-	-	-	-	180	180	180
90	104	104	104	520	145	145	145	145	200	240	210	270	200
-	-	-	-	700	700	700	700	700	700	700	700	700	-
400/500	400/500	400/500	400/500	1060/1270	750/990	750/990	750/990	750/990	860/985	860/985	1250/1500	750/900	1280/1540
✓	✓	✓	✓	✓	✓	✓	✓	✓	✓	✓	✓	-	✓
✓	✓	✓	✓	✓	✓	✓	✓	✓	✓	✓	✓	✓	✓
-	-	-	-	✓	-	-	-	-	✓	✓	✓	-	-
✓	✓	✓	✓	✓	✓	✓	✓	✓	✓	✓	✓	✓	✓
✓	✓	✓	✓	✓*	✓	-	✓	-	✓	✓	✓	✓*	✓
-	-	-	-	28.5	-	-	-	-	36.8	36.8	21.2	-	-
-	-	-	-	250	-	-	-	-	170	170	270	-	-
-	-	-	-	-	-	-	-	-	-	-	-	-	-
-	-	-	-	390.5	-	-	-	-	161	161	176.1	-	-
-	-	-	-	10	-	-	-	-	12	12	14	-	-
7.8	5.6	8.1	7.8	11.6	6.2	10.0	6.2	10.0	6.1	6.1	9.6	7.7	10.0
353	300	400 (194 behind NSHF)	353	300	342	366	342	366	325	325	330	245	350 (218 behind NSHF)
12	12	12	12	12	12	13	12	13	12	12	12	12	12
10.7	8.7	8.7	10.7	8.6	10.5	9.5	10.5	9.5	10.8	10.8	10.0	8.3	10.0
15	15	15	15	15	15	15	15	15	15	15	15	15	15
26.2	18.1	30.4	26.2	39.8	20.7	36.6	20.7	36.6	19.7	19.7	36.5	26.4	36.5
10	10	10	10	10	10	10	10	10	10	10	12	8	13
0	0	0	0	0	0	0	0	0	0	0	0	0	0
0	0	0	0	5	0	0	0	0	0	0	0	0	0
0	0	0	0	0	10	10	10	10	13	13	7	13	7
11	11	11	11	10	10	10	10	10	9	9	7	11	7
10	10	10	10	10	10	10	10	10	10	10	10	10	10
0	0	0	0	4	0	0	0	0	0	0	0	0	0
0	0	0	0	0	8	8	8	8	10	10	6	10	6
9	9	9	9	8	8	8	8	8	7	7	6	9	6
61	61	61	61	48	54	54	54	54	42	42	53	53	53
39	39	39	39	52	46	46	46	46	58	58	47	47	47
0	0	0	0	0	0	0	0	0	0	0	0	0	0

Changes and mistakes reserved

* Fulfills 15a 2015 only with AT hand piece, attention: flue gas connection + 160 mm

*** Values were not available at the time of printing.

*** Deviating insulation guidelines apply for GET fireproof inserts. This can be obtained from the separate GET manual.

11. TECHNICAL DATA

		Varia 2Lh / 2Rh	Varia 2Lh / 2Rh	Varia 2Lh / 2Rh NSHF	Varia AS 2Lh/2Rh	Varia AS 2Lh/2Rh (Export)	Varia 2LR-80h	Varia 2LR-80h (Export)	Varia 2L / 2R 100h
General data	Nominal heat output kW (closed operation)	11.0	7.0	12.0	7.0	11.0	10.4	16.0	11.0
	Thermal output range kW	7.7-14,3	4.9-9,1	8.4-15,6	4.9-9,1	7.7-14,3	7.2-13,5	11.2-20,8	7.7-14,3
	Efficiency %	80	> 78	80	80	80	> 80	> 80	>78
	Required chimney diameter (mm)	200	200	200	200	200	200	200	250
	Flue gas connection: Ø mm	200	200	200	200	200	200	200	250
	Possible flue gas connection Ø mm	180	180	180	180	180	180	180	200
	Weight (approx.) kg	270	270	270	212	181	275	275	280
	Required minimum cross-section for supply and recirculating air (with WLM) cm ²	700	700	-	700	700	700	700	700
Required minimum cross-section for recirculating and supply air (without WLM) cm ²	1250/1500	750/900	1280/1540	1200/1400	1200/1400	1200/1400	1200/1400	1140/1350	
Testing and values	non-self-closing combustion chamber door (Design A)	✓	-	✓	✓	✓	✓	✓	✓
	self-closing combustion chamber door (Design A1)	✓	✓	✓	✓	✓	✓	✓	✓
	Operation with open combustion chamber door	✓	-	-	-	-	-	-	✓
	Level 2 BImSchV (Ordinance in the Implementation of the Federal Immission Control Act)	✓	✓	✓	✓	✓	✓	✓	✓
	15a BvG	✓	✓*	✓	✓	✓	✓	-	✓*
Operation with open combustion chamber (multiple allocation not permitted)	Mass flow of flue gas g/s	21.2	-	-	-	-	-	-	20.2
	Flue gas temperature °C	270	-	-	-	-	-	-	210
	Flue gas temperature behind the NSHF °C	-	-	-	-	-	-	-	-
	Combustion air requirement m ³ /h	176.1	-	-	-	-	-	-	207.5
	Required supply pressure: in Pa	14	-	-	-	-	-	-	10
Operation with closed combustion chamber (multiple allocation permitted)	Mass flow of flue gas g/s	9.6	7.7	10.0	6.6	8.7	9.5	12.9	12.0
	Flue gas temperature °C (on the flue gas outlet)	330	245	350 (218 behind NSHF)	311	349	283	305	280
	Required supply pressure: in Pa	12	12	12	12	12	12	12	12
	CO ₂ %	10.0	8.3	10.0	11.2	9.7	10.1	10.9	8.2
	Required diameter after M-FeuVo. cm	15	15	15	15	15	15	15	15
	Combustion air requirement m ³ /h	36.5	33.5	36.5	19	34.5	31.3	44.7	41.1
Heating chamber distance	to the heating chamber wall cm	12	8	13	10	10	10	10	10
	To the setup floor cm	0	0	0	0	0	0	0	0
Heat insulation (example rock wool matting to AGI-Q 132)	Setup floor cm	0	0	0	0	0	0	0	5
	Mounting wall cm	7	13	7	11	11	16	16	10
	Side wall cm	7	11	7	11	11	16	16	10
	Stud wall with a wall that must be protected cm	10	10	10	10	10	10	10	10
Substitute insulation material, calcium silicate	Setup floor cm	0	0	0	0	0	0	0	4
	Mounting wall cm	6	10	6	9	9	12	12	8
	Side wall cm	6	9	6	9	9	12	12	8
Heat distribution	Convection %	53	51	53	58	58	53	53	49
	Viewing panel %	47	49	47	42	42	47	47	51
	H ₂ O %	0	0	0	0	0	0	0	0

Changes and mistakes reserved

* Fulfills 15a 2015 only with AT hand piece, attention: flue gas connection + 160 mm

*** Values were not available at the time of printing.

*** Deviating insulation guidelines apply for GET fireplace inserts. This can be obtained from the separate GET manual.

Varia 2L / 2R 55h GET	Varia 2L / 2R 55h GET DH	Varia 2LRh / RRh 55	Varia 2LRh / RRh	Varia 2L / 2Lh / 2R / 2Rh / 2LRh / RRh NSHF	Arte 2LRh-66	Arte 2LRh-66 mit NSHF	Arte 2LRh-66 (Export)	Varia C-45h	Varia Ch	Arte U-50h	Arte U-70h	Arte U-90h	Arte 3RL-60h
7.0	7.0	7.0	11.0	12.0	6.5	10.4	12.0	8.0	9.0	9.0	11.0	13.0	7.5
4.9-9,1	4.9-9,1	4.9-9,1	7.7-14,3	8.4-15,6	4.6-8,5	7.3-13,5	8.4-15,6	5.6-10,4	6.3-11,7	6.3-11,7	7.7-14,3	9.1-16,9	5.3-9,8
> 80	> 80	> 80	80	80	>80	>80	>80	> 80	80	80	>78	>78	> 80
180	180	180	200	200	180	180	180	180	250	250	250	250	250
180	180	180	200	200	180	180	180	180	250	250	250	250	250
-	-	-	180	180	-	-	-	-	200	200	200	200	200
230	260	240	270	270	175	175	175	170	300	351	375	426	250
-	-	700	700	-	700	-	700	700	700	-	-	-	-
810/970	810/970	860/985	1250/1500	1280/1540	626/750	626/750	626/750	1120/1470	880/1070	630/760	810/970	940/1130	630/760
-	-	✓	✓	✓	✓	✓	✓	-	✓	-	-	-	✓
✓	✓	✓	✓	✓	✓	✓	✓	-	✓	✓	✓	✓	✓
-	-	✓	✓	-	-	-	-	-	✓	-	-	-	✓
✓	✓	✓	✓	✓	✓	✓	✓	✓	✓	✓	✓	✓	✓
✓	✓	✓	✓	✓	✓	✓	✓	✓	✓	✓	✓*	✓*	✓
-	-	36.8	21.2	-	-	-	-	-	18.4	-	-	-	23.7
-	-	170	270	-	-	-	-	-	240	-	-	-	140
-	-	-	-	-	-	-	-	-	-	-	-	-	-
-	-	161	176.1	-	-	-	-	-	199.8	-	-	-	178.7
-	-	12	14	-	-	-	-	-	10	-	-	-	7
6.5	6.5	6.1	9.6	10.0				7.5	8.8	8.6	11.3	13.4	7.0
276	276	325	330	350 (218 behind NSHF)				255	340	310	310	310	310
12	12	12	12	12				12	14	12	12	12	12
9.7	9.7	10.8	10.0	10.0	6.6	**	9.3	9.2	9.7	9.3	9.2	9.2	9.3
15	15	15	15	15	275	**	350	15	15	15	15	15	15
22.6	22.6	19.7	36.5	36.5	12	**	12	25.8	28.3	29.6	37.1	44.0	23.4
7	7	10	12	13	**	**	**	12	9	8	9	10	5
0	0	0	0	0	**	**	**	0	0	0	0	0	0
0	0	0	0	0	**	**	**	0	0	0	5	5	0
***15	0	13	7	7	**	**	**	11	8	6	9	9	9
***6	0	9	7	7	**	**	**	9	8	6	6	6	9
***10	0	10	10	10	**	**	**	10	10	10	10	10	10
0	0	0	0	0	**	**	**	0	0	0	4	4	0
***12	0	10	6	6	**	**	**	9	6	5	7	7	7
***5	0	7	6	6	**	**	**	7	6	5	5	5	7
50	50	42	53	53	63	63	63	56	52	35	37	36	42
50	50	58	47	47	37	37	37	44	48	65	63	64	58
0	0	0	0	0	0	0	0	0	0	0	0	0	0

Changes and mistakes reserved

* Fulfills 15a 2015 only with AT hand piece, attention: flue gas connection + 160 mm

*** Values were not available at the time of printing.

*** Deviating insulation guidelines apply for GET fireplace inserts.
This can be obtained from the separate GET manual.

11. TECHNICAL DATA

	Arte 3RL-80h	Arte 3RL-100h	Speedy MR	Speedy MR S	Speedy MRh	Speedy MRh S	Speedy R	Speedy R NSHF	
General data	Nominal heat output kW (closed operation)	9.0	11.0	9.0	7.0	9.0	7.0	9.0	10.0
	Thermal output range kW	6.3-11,7	7.7-14,3	6.3-11,7	4.9-9,1	6.3-11,7	4.9-9,1	6.3-11,7	7.0-13,0
	Efficiency %	> 80	>78	> 80	> 80	> 80	> 80	> 78	> 80
	Required chimney diameter (mm)	250	250	180	180	180	180	200	200
	Flue gas connection: Ø mm	250	250	180	180	180	180	200	200
	Possible flue gas connection Ø mm	200	200	-	-	-	-	180	180
	Weight (approx.) kg	351	371	200	200	240	200	180	210
	Required minimum cross-section for supply and recirculating air (with WLM) cm ²	-	-	700	700	700	700	700	-
Required minimum cross-section for recirculating and supply air (without WLM) cm ²	770/920	930/1110	1110/1330	810/970	1110/1330	810/970	780/930	780/930	
Testing and values	non-self-closing combustion chamber door (Design A)	✓	✓	✓	-	✓	-	✓	-
	self-closing combustion chamber door (Design A1)	✓	✓	✓	✓	✓	✓	✓	✓
	Operation with open combustion chamber door	✓	✓	-	-	-	-	✓	-
	Level 2 BImSchV (Ordinance in the Implementation of the Federal Immission Control Act)	✓	✓	✓	✓	✓	✓	✓	✓
	15a BvG	✓	✓*	✓	✓	✓	✓	✓*	✓
Operation with open combustion chamber (multiple allocation not permitted)	Mass flow of flue gas g/s	26.5	40	-	-	-	-	26.4	-
	Flue gas temperature °C	155	180	-	-	-	-	257	-
	Flue gas temperature behind the NSHF °C	-	-	-	-	-	-	-	-
	Combustion air requirement m ³ /h	243.5	314.1	-	-	-	-	120.4	-
	Required supply pressure: in Pa	7	12	-	-	-	-	12	-
Operation with closed combustion chamber (multiple allocation permitted)	Mass flow of flue gas g/s	7.3	10.3	7.1	6.2	7.1	6.2	9.2	10.7
	Flue gas temperature °C (on the flue gas outlet)	335	360	360	341	360	341	336	430 (233 behind NSHF)
	Required supply pressure: in Pa	12	12	12	12	12	12	12	12
	CO ₂ %	10.1	9.8	11.7	9.9	11.7	9.9	9.2	7.5
	Required diameter after M-FeuVo. cm	15	15	15	15	15	15	15	15
	Combustion air requirement m ³ /h	26.8	35	23.3	21.6	23.3	21.6	30.6	34
Heating chamber distance	to the heating chamber wall cm	4	10	12	12	12	12	11	9
	To the setup floor cm	0	0	0	0	0	0	0	0
Heat insulation (example rock wool matting to AGI-Q 132)	Setup floor cm	0	4	0	0	0	0	4	4
	Mounting wall cm	9	11	9	9	9	9	6	6
	Side wall cm	9	11	9	9	9	9	6	6
	Stud wall with a wall that must be protected cm	10	10	10	10	10	10	10	10
Substitute insulation material, calcium silicate	Setup floor cm	0	3	0	0	0	0	3	3
	Mounting wall cm	7	9	7	7	7	7	5	5
	Side wall cm	7	9	7	7	7	7	5	5
Heat distribution	Convection %	43	42	46	46	46	46	52	52
	Viewing panel %	57	58	54	54	54	54	48	48
	H ₂ O %	0	0	0	0	0	0	0	0

Changes and mistakes reserved

* Fulfills 15a 2015 only with AT hand piece, attention: flue gas connection + 160 mm

*** Values were not available at the time of printing.

*** Deviating insulation guidelines apply for GET fireplace inserts. This can be obtained from the separate GET manual.

Speedy Rh	Speedy Rh NSHF	Speedy Ph 4S	Magic	Speedy MDRh	Varia Eh	Arte BRh	Speedy M	Speedy M NSHF	Speedy Mh	Speedy Mh NSHF	Speedy K	Speedy K NSHF	Speedy Kh
9.0	10.0	7.0	12.0	9.0	11.0	11.0	8.0	9.0	8.0	9.0	9.0	10.0	9.0
6.3-11,7	7.0-13,0	4.9-9,1	8.4-15,6	6.3-11,7	7.7-14,3	7.7-14,3	5.6-10,4	6.3-11,7	5.6-10,4	6.3-11,7	6.3-11,7	7.0-13,0	6.3-11,7
> 78	> 80	> 80	80	>78	>78	>78	> 80	> 80	> 80	> 80	78	> 80	78
200	200	160	180	200	200	200	180	180	180	180	200	200	200
200	200	160	180	200	200	200	180	180	180	180	200	200	200
180	180	-	-	180	180	180	-	-	-	-	180	180	180
210	210	180	295	300	300	280	180	190	210	190	180	220	180
700	-	700	700	700	700	700	700	-	700	-	700	-	700
780/930	780/930	630/750	260/430	810/980	1330/1600	1110/1330	830/990	960/1150	830/990	960/1150	1100/1320	1230/1470	1100/1320
✓	-	✓	-	✓	✓	✓	✓	-	✓	-	✓	-	✓
✓	✓	✓	✓	✓	✓	✓	✓	✓	✓	✓	✓	✓	✓
✓	-	-	-	✓	✓	✓	-	-	-	-	✓	-	✓
✓	✓	✓	✓	✓	-	✓	✓	✓	✓	✓	✓	✓	✓
✓*	✓	-	✓	✓*	✓*	✓*	✓	✓	✓	✓	✓*	✓	✓*
26.4	-	-	-	28.4	22.1	22.4	-	-	-	-	26.4	-	26.4
257	-	-	-	210	270	260	-	-	-	-	257	-	257
-	-	-	-	-	-	-	-	-	-	-	-	-	-
120.4	-	-	-	161.2	108.1	179	-	-	-	-	123.1	-	123.1
12	-	-	-	10	10	10	-	-	-	-	12	-	12
9.2	10.7	5.7	9.0	9.4	10.0	10.7	5.4	8.8	5.4	8.8	9.2	10.7	9.2
336	430 (233 behind NSHF)	290	370	310	330	350	324	330 (240 behind NSHF)	324	330 (240 behind NSHF)	336	330 (233 behind NSHF)	336
12	12	12	11	12	12	12	12	12	12	12	12	12	12
9.2	7.5	10.5	11.6	9.2	9.6	9.7	13.1	9.1	13.1	9.1	9.2	7.5	9.2
15	15	15	15	15	15	15	15	15	15	15	15	15	15
30.6	34	25.7	29	30.4	35.6	35.2	18.2	29.1	18.2	29.1	30.6	39.6	30.6
11	9	9	9	12	12	7	12	13	12	13	13	10	13
0	0	0	0	0	0	0	0	0	0	0	0	0	0
4	4	0	0	10	0	0	0	0	0	0	4	4	4
6	6	8	11	10	8	11	12	8	12	8	6	6	6
6	6	8	0	10	8	11	12	8	12	8	6	6	6
10	10	10	10	10	10	10	10	10	10	10	10	10	10
3	3	0	0	8	0	0	0	0	0	0	3	3	3
5	5	6	9	8	6	9	9	6	9	6	5	5	5
5	5	6	0	8	6	9	9	6	9	6	5	5	5
52	52	40	47	45	61	51	51	51	51	51	60	69	60
48	48	60	53	55	39	49	49	49	49	49	40	31	40
0	0	0	0	0	0	0	0	0	0	0	0	0	0

Changes and mistakes reserved

* Fulfills 15a 2015 only with AT hand piece, attention: flue gas connection + 160 mm

*** Values were not available at the time of printing.

*** Deviating insulation guidelines apply for GET fireproof inserts.
This can be obtained from the separate GET manual.

11. TECHNICAL DATA

		Speedy Kh NSHF
General data	Nominal heat output kW (closed operation)	10.0
	Thermal output range kW	7.0-13,0
	Efficiency %	> 80
	Required chimney diameter (mm)	200
	Flue gas connection: Ø mm	200
	Possible flue gas connection Ø mm	180
	Weight (approx.) kg	220
	Required minimum cross-section for supply and recirculating air (with WLM) cm ²	-
	Required minimum cross-section for recirculating and supply air (without WLM) cm ²	1230/1470
Testing and values	non-self-closing combustion chamber door (Design A)	-
	self-closing combustion chamber door (Design A1)	✓
	Operation with open combustion chamber door	-
	Level 2 BImSchV (Ordinance in the Implementation of the Federal Immission Control Act)	✓
	15a BVG	✓
Operation with open combustion chamber (multiple allocation not permitted)	Mass flow of flue gas g/s	-
	Flue gas temperature °C	-
	Flue gas temperature behind the NSHF °C	-
	Combustion air requirement m ³ /h	-
	Required supply pressure: in Pa	-
Operation with closed combustion chamber (multiple allocation permitted)	Mass flow of flue gas g/s	10.7
	Flue gas temperature °C (on the flue gas outlet)	330 <small>(233 behind NSHF)</small>
	Required supply pressure: in Pa	12
	CO ₂ %	7.5
	Required diameter after M-FeuVo. cm	15
	Combustion air requirement m ³ /h	39.6
Heating chamber distance	to the heating chamber wall cm	10
	To the setup floor cm	0
Heat insulation (example rock wool matting to AGI-Q 132)	Setup floor cm	4
	Mounting wall cm	6
	Side wall cm	6
	Stud wall with a wall that must be protected cm	10
Substitute insulation material, calcium silicate	Setup floor cm	3
	Mounting wall cm	5
	Side wall cm	5
Heat distribution	Convection %	69
	Viewing panel %	31
	H ₂ O %	0

Changes and mistakes reserved

* Fulfills 15a 2015 only with AT hand piece, attention: flue gas connection + 160 mm

*** Values were not available at the time of printing.

*** Deviating insulation guidelines apply for GET fireplace inserts.
This can be obtained from the separate GET manual.

11. TECHNICAL DATA, CLASSIC

	Nova E H2O with NSHF	Nova F - Air with NSHF	Renova A H2O with NSHF	Renova B - Air with NSHF	Renova C - Air with NSHF (wood logs)	Renova C - Air with NSHF (lignite)	
General data	Nominal heat output kW (closed operation)	14.0 / water side 9.0	10,1	13.4 / water side 6.9	8,8	8,5	7,8
	Thermal output range kW	9.8-18,2	7.1-13,1	9.4-17,4	6.2-11,4	6.0-11,1	5.5-10,1
	Efficiency %	> 80	> 80	> 80	> 80	> 80	> 80
	Required chimney diameter (mm)	180	180	180	180	160	160
	Flue gas connection: Ø mm	180	180	180	180	160	160
	Possible flue gas connection Ø mm	-	150	150	150	150/180	150/180
	Weight (approx.) kg	290	195	200	140	105	110
	Required minimum cross-section for supply and recirculating air (with WLM) cm ²	-	-	-	-	-	-
	Required minimum cross-section for recirculating and supply air (without WLM) cm ²	370/450	1580/1900	690/830	1060/1280	1030/1240	1030/1240
Testing and values	non-self-closing combustion chamber door (Design A)	-	-	-	-	-	-
	self-closing combustion chamber door (Design A1)	✓	✓	✓	✓	✓	✓
	Operation with open door	-	-	-	-	-	-
	BimSchV [Ordinance in the Implementation of the Federal Immission Control Act] 1st level	✓	✓	✓	✓	✓	✓
	BimSchV [Ordinance in the Implementation of the Federal Immission Control Act] 2nd level	✓	✓	✓	✓	✓	✓
	15a BVG	✓	✓	✓	✓	✓	✓
Operation with closed combustion chamber (multiple allocation permitted)	Mass flow of flue gas g/s	12.7	9.2	12.8	9.4	8.2	9.1
	Flue gas temperature °C (on the flue gas outlet)	<small>Outflow top: 193 Outflow to the side: 343 (166 behind NSHF)</small>	355	<small>396 (165 behind NSHF)</small>	357	<small>495 (142 behind NSHF)</small>	<small>483 (142 behind NSHF)</small>
	Required supply pressure: in Pa	12	12	12	12	12	12
	CO ₂ %	8.2	8.1	7.7	7.0	7.7	7.1
	Required diameter after M-FeuVo. cm	15	15	15	15	15	15
Triple value for the chimney calculation when connecting to downstream lines	Combustion air requirement m ³ /h	46,3	34,1	47,3	34,7	30,3	30,3
	Mass flow of flue gas g/s	25	26	25	25	20	20
	Flue gas temperature at the insert connecting piece °C	520	600	480	590	650	650
	Required supply pressure Pa	14	15	12	15	15	15
	CO ₂ %	~ 9	~ 9	~ 9	~ 9	~ 9	~ 9
	Fuel amount kg/h	10	8	8	7	4	4
Operation with open fireplace (multiple allocation not permitted)	Combustion air requirement m ³ /h	103	77	82	68	41	41
	Mass flow of flue gas g/s	-	-	-	-	-	-
	Flue gas temperature °C	-	-	-	-	-	-
	Flue gas temperature behind the NSHF °C	-	-	-	-	-	-
	Combustion air requirement m ³ /h	-	-	-	-	-	-
Heating chamber distance	Required supply pressure: in Pa	-	-	-	-	-	-
	to the heating chamber wall cm	6	6	6	10	10	10
Heat insulation (example rock wool matting to AGI-Q 132)	To the setup floor cm	0	0	0	0	0	0
	Setup floor cm	0	0	0	0	0	0
	Mounting wall cm	10	13	12	13	15	15
	Side wall cm	10	13	12	13	15	15
	Primary walling for wall that must be protected cm	6	6	6	6	6	6
Heat insulation (example calcium silicate according to EN 13501-2)	Setup floor cm	0	0	0	0	0	0
	Mounting wall cm	8	10	9	10	12	12
	Side wall cm	8	10	9	10	12	12
	Primary walling for wall that must be protected cm	6	6	6	6	6	6
	as a replacement for the front-mounted masonry and thermal insulation for the mounting wall cm	10	13	12	13	15	15
	as a replacement for the front-mounted masonry and thermal insulation for the side wall cm	10	13	12	13	15	15

Changes and mistakes reserved

* Fulfills 15a 2015 only with AT hand piece, attention: flue gas connection + 160 mm

*** Values were not available at the time of printing.

*** Deviating insulation guidelines apply for GET fireplace inserts. This can be obtained from the separate GET manual.

